

# Uniblitz® CS25

## 25mm Uni-Stable Optical Shutter

### Overview

The Uniblitz CS25 has been designed to provide accurate, repeatable exposures for a wide variety of applications including microscopy, video imaging, and more. The slim form-factor provides a 25mm aperture that can be inserted into a 2.37 inch diameter housing. The CS25 is available in a housed or an un-housed configuration for OEM applications (or simply where spatial limitations are a consideration).

Uni-stable shutter devices, like the CS25, require power to hold the blades in the open state.

### Key Features

- 25mm aperture
- Configured for the [VCM-D1 Shutter Driver](#)
- **RoHS Compliant**
- Transfer time on opening: 9.0 milliseconds
- Transfer time on closing: 14.0 milliseconds

### Specifications

#### Electrical Specifications

Coil resistance	12 OHMS
Voltage to Open	+65 VDC <sup>1</sup>
Hold Voltage (Nominal) <sup>2</sup>	+5 VDC

#### Mechanical Specifications

Weight Unhoused	36.3 g
Weight Housed	89.6 g
Operating Temp.	0 - 80 °C
Max. Opening Bounce	15%
Max. Closing Bounce	5%
Max. Freq. of Operation <sup>3</sup>	5 Hz / 30 Hz
Number of Shutter Blades	5

<sup>1</sup> VCM-D1 Standard Energy Mode provides this voltage level (Capacitor value: 330µf).

<sup>2</sup> Voltage level required across actuator coil when being held in the open position.

<sup>3</sup> (Continuous/Burst) Continuous frequency rating specified at shutter's minimum exposure pulse. Burst frequency rating specified for four (4) seconds maximum with one (1) minute minimum between bursts.

## Shutter Timing Data

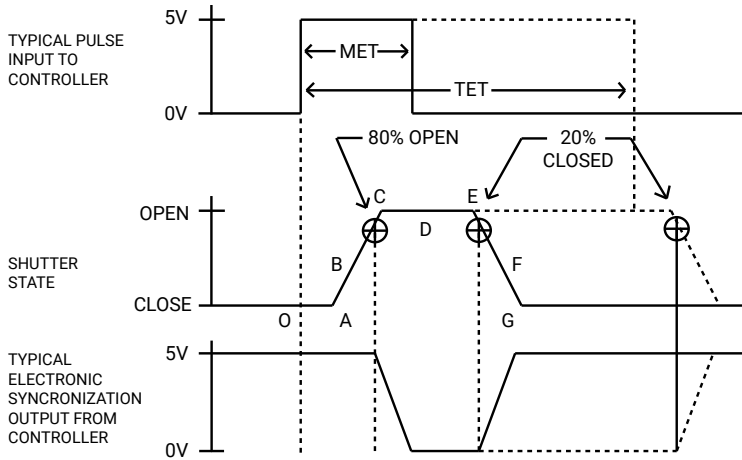

### MET<sup>1</sup> and TET<sup>2</sup> for CS25

- **Minimum Exposure Time (MET):**  
15.0 msec.<sup>3</sup>
- **Typical Exposure Time (TET):**  
40.0 msec.<sup>3</sup>

CS25 <sup>4</sup> (w/ VCM-D1 and "T" blades) <sup>5</sup>		Min. Exp. Time (15.0 msec.)		Typ. Exp. Time (40.0 msec.)	
Graph	Description	Mean	Max	Mean	Max
O - A	Delay time on opening after current is applied	4.0	5.0	4.0	5.0
A - C	Transfer time on opening	9.0	10.0	9.0	10.0
O - C	Total opening time	13.0	15.0	13.0	15.0
B - F	Minimum equivalent exposure time	16.5	19.5	52.0	55.0
C - E	Minimum dwell time (based on exposure pulse)	5.0	6.0	35.0	36.0
D - E	Delay time on closing after current is removed	3.0	6.0	8.0	11.0
E - G	Transfer time on closing	14.0	17.0	25.0	28.0
A - G	Total window time	28.0	33.0	69.0	74.0

<sup>1</sup> The minimum exposure pulse required to achieve a full opening and closing.

<sup>2</sup> The exposure pulse required to ensure that the A - G time will change linearly with the exposure pulse (E.g. 1.0 msec changes in exposure pulse beyond 40.0 msec will provide 1.0 msec changes in A-G time).

<sup>3</sup> Due to non-linearity caused by damp and blade adjustment, exposure pulse selection between 15.0 msec and 40.0 msec may have some indeterminate typical and max values.

<sup>4</sup> Individual timing segments may vary.

<sup>5</sup> Under no circumstances should any type of lubricant be applied to the shutter blade area. Lubricating the shutter blades will likely slow the shutter down and may eventually render it inoperable.

## Product Options

CS25 **2** **3** **4** **5** **6** - **7** - **8**

Ex: CS25S3T0-EC-21

<p><b>1 Shutter Series:</b></p> <p>CS25</p>	<p><b>2 Voltage:</b></p> <p>S: Use with VCM-D1</p> <p>E: Use with V880, VED24, or D880C</p>	<p><b>3 Housing:</b></p> <p>1: Un-Housed</p> <p>3: #3 Housing</p>	<p><b>4 Blades:</b> <sup>2</sup></p> <p>T: Low Energy (Teflon®)</p> <p>ZM: High Energy (AlMgF2) <sup>3</sup></p>
<p><b>5 Electronic Sync:</b></p> <p>0: Omitted</p> <p>1: Included</p>	<p><b>6 Connector:</b></p> <p>L: 18" Flying Leads</p> <p><i>Leave blank for 5-pin Switchcraft connector</i></p>	<p><b>7 Encapsulated Coil:</b></p> <p>EC: Included</p> <p><i>Leave blank if not required</i></p>	<p><b>8 Mount:</b> <sup>4</sup></p> <p>21: Zeiss Axiovert    105: C-Mount (Male)</p> <p>24: Olympus BX/IX    106: C-Mount (Female)</p> <p>27: Nikon    <i>Leave blank if not required</i></p>

<sup>2</sup> Other blade coating options may be available by special order.

<sup>3</sup> Input side only; Teflon® coating is on opposite side to protect shutter blade surface. Light source must be input to the reflective side only.

<sup>4</sup> Mounts are only compatible if #3 housing is optioned as well.

## Electronic Sync.

The synchronization system for CS25 shutter devices incorporates a small magnet mounted to the driving mechanism and a Hall Effect sensor. When the device achieves approximately 80% of full open, the magnet causes the Hall effect sensor to change state, producing a signal to indicate that the shutter has switched to the active state. Shown is the CS25 series shutter schematic which incorporates this electronic synchronization system. **There is no connection to the designated synchronization pins when an electronic sync. is omitted.**

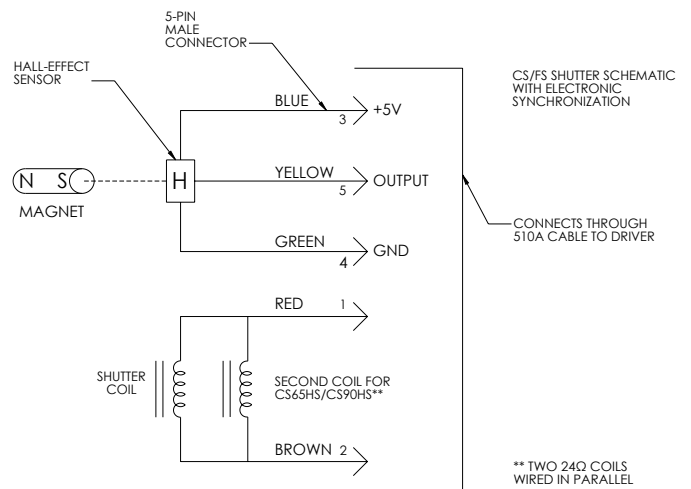

# Uniblitz® CS25 Technical Drawings

## Un-Housed

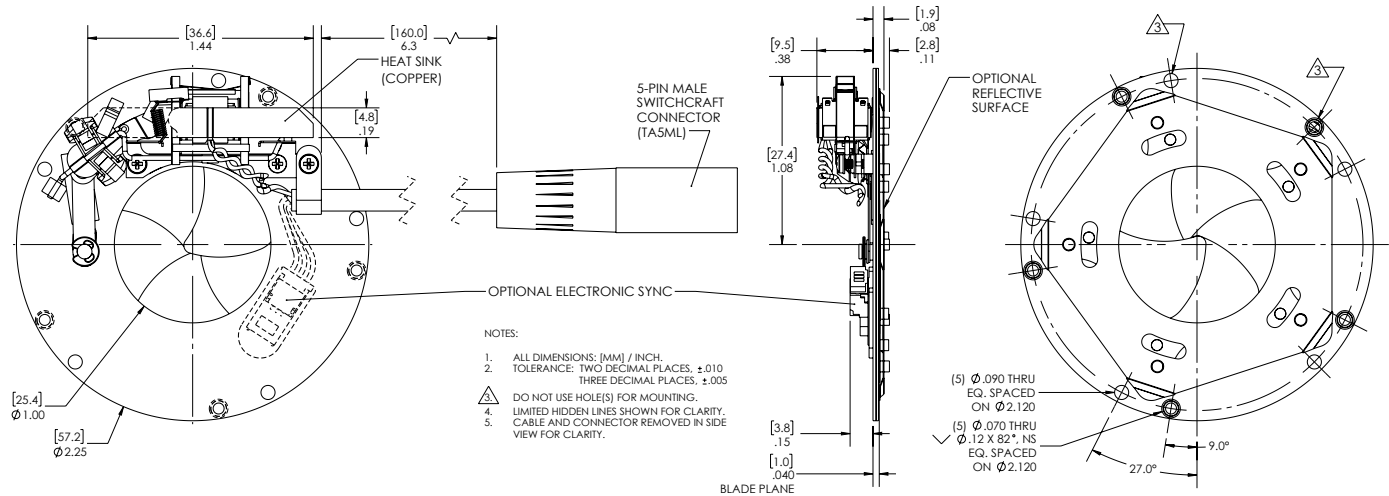

## Housed / Connector Layout

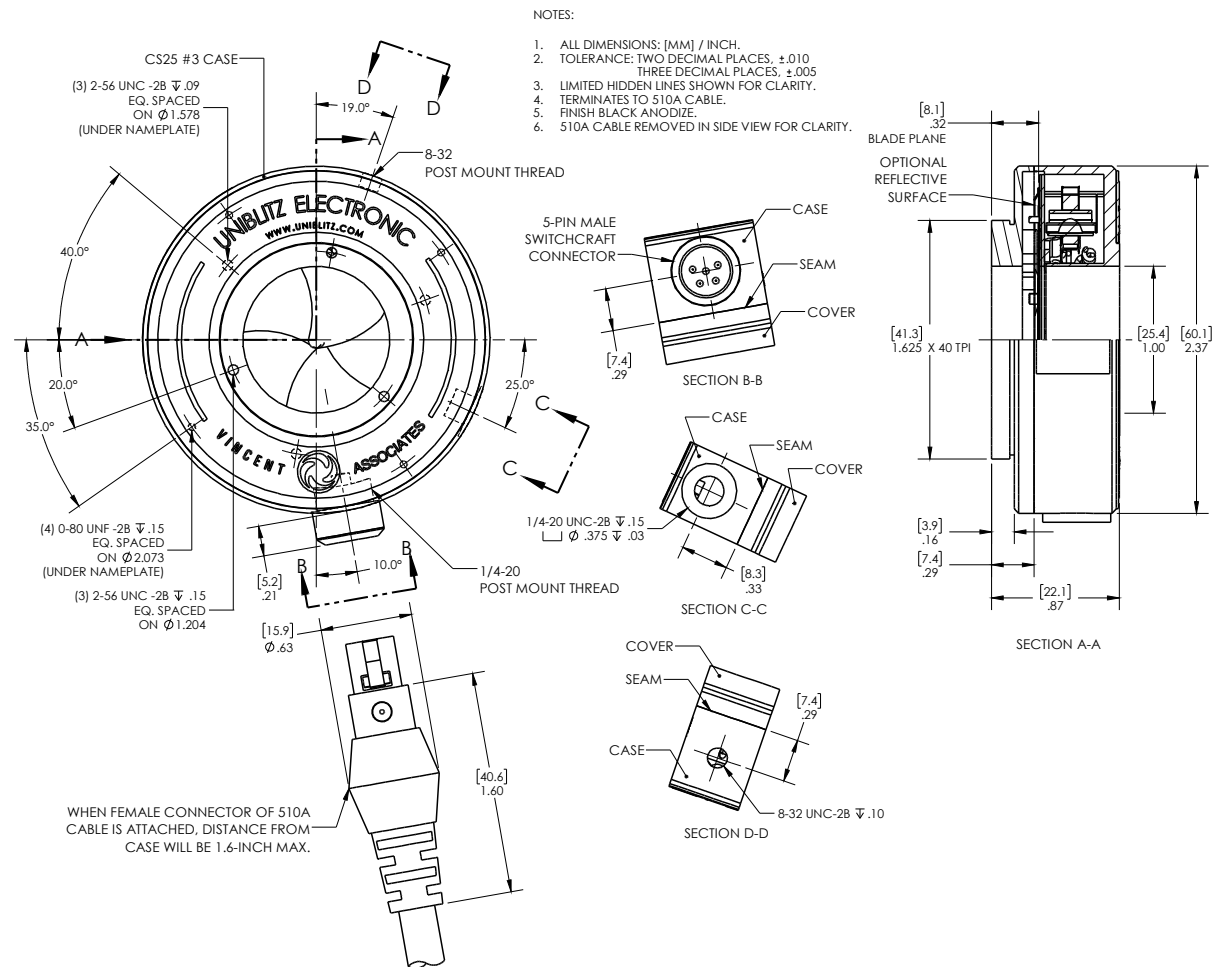

# Uniblitz® CS25 Technical Drawings

## 501A-S7 Adapter Cable<sup>1</sup> (Not included)

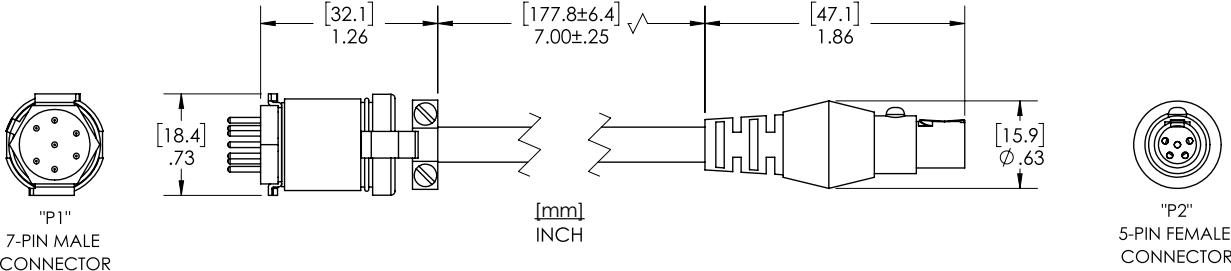

<sup>1</sup> 501A-S7 Shutter Adapter Cable is required for use with VMM-D3, VMM-D4, D880C and any VCM-D1 purchased prior to November 2022.