

Uniblitz® CS45

45mm Uni-Stable Optical Shutter

Overview

The Uniblitz CS45 has been designed to provide accurate, repeatable exposures for a wide variety of applications including microscopy, video imaging, and more. The slim form-factor provides a 45mm aperture that can be inserted into a 3.33 inch diameter housing. The CS45 is available in a housed or an un-housed configuration for OEM applications (or simply where spatial limitations are a consideration).

Uni-stable shutter devices, like the CS45, require power to hold the blades in the open state.

Key Features

- Large 45mm aperture
- Slim form-factor
- Configured for the [VCM-D1 Shutter Driver](#)
- **RoHS Compliant**
- Transfer time on opening: 17.5 milliseconds
- Transfer time on closing: 23.0 milliseconds

Specifications

Electrical Specifications

Coil resistance	12 OHMS
Voltage to Open	+70 VDC
Hold Voltage (Nominal) ¹	+7 VDC / +5 VDC ²

Mechanical Specifications

Weight Unhoused	90.0 g
Weight Housed	260.0 g
Operating Temp.	0 - 80 °C
Max. Opening Bounce	15%
Max. Closing Bounce	5%
Max. Freq. of Operation ³	2.5 Hz / 15 Hz
Number of Shutter Blades	5

¹ Voltage level required across actuator coil when being held in the open position.

² Dual hold voltage system included in VCM-D1 shutter driver.

³ (Continuous/Burst) Continuous frequency rating specified at shutter's minimum exposure pulse. Burst frequency rating specified for four (4) seconds maximum with one (1) minute minimum between bursts.

Shutter Timing Data

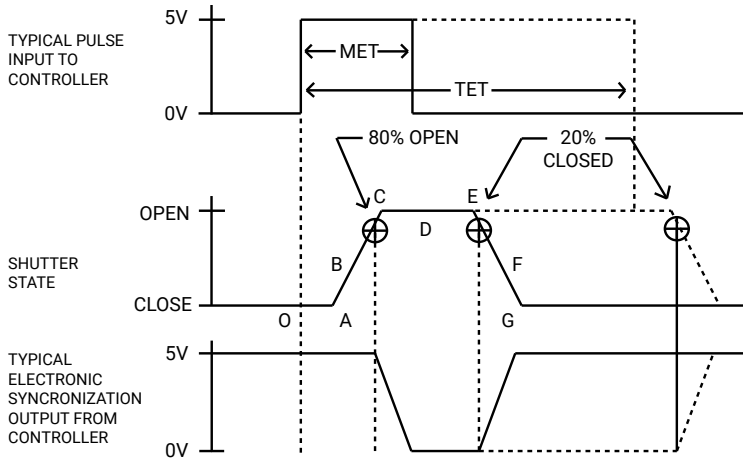

MET¹ and TET² for CS45

- **Minimum Exposure Time (MET):**
30.0 msec.³
- **Typical Exposure Time (TET):**
80.0 msec.³

CS45 ⁴ (w/ VCM-D1 and "T" blades) ⁵		Min. Exp. Time (msec.)		Typ. Exp. Time (msec.)	
Graph	Description	Mean	Max	Mean	Max
O - A	Delay time on opening after current is applied	6.5	7.5	6.5	7.5
A - C	Transfer time on opening	17.5	18.0	17.5	18.0
O - C	Total opening time	24.0	25.5	24.0	25.5
B - F	Minimum equivalent exposure time	34.3	36.0	94.3	95.8
C - E	Minimum dwell time (based on exposure pulse)	14.0	15.0	70.0	70.0
D - E	Delay time on closing after current is removed	8.0	10.5	14.0	15.5
E - G	Transfer time on closing	23.0	24.0	31.0	33.5
A - G	Total window time	54.5	57.0	118.5	121.5

¹ The minimum exposure pulse required to achieve a full opening and closing.

² The exposure pulse required to ensure that the A - G time will change linearly with the exposure pulse (E.g. 1 msec changes in exposure pulse beyond 80 msec will provide 1 msec changes in A-G time).

³ Due to non-linearity caused by damp and blade adjustment, exposure pulse selection between 30 msec and 80 msec may have some indeterminate typical and max values.

⁴ Individual timing segments may vary.

⁵ Under no circumstances should any type of lubricant be applied to the shutter blade area. Lubricating the shutter blades will likely slow the shutter down and may eventually render it inoperable.

Product Options

CS45 **2** **3** **4** **5** **6** - **7** - **8**

Ex: CS45S3T0-EC-101

<p>1 Shutter Series:</p> <p>CS45</p>	<p>2 Driver Compatibility:</p> <p>S: Use with VCM-D1</p> <p>E: Use with V880, VED24, or D880C</p>	<p>3 Housing:</p> <p>1: Un-Housed</p> <p>3: #3 Housing</p>	<p>4 Blades: ²</p> <p>T: Low Energy (Teflon®)</p> <p>ZM: High Energy (AlMgF2) ³</p>
<p>5 Electronic Sync:</p> <p>0: Omitted</p> <p>1: Included</p>	<p>6 Connector:</p> <p>L: 18" Flying Leads</p> <p><i>Leave blank for 5-pin Switchcraft connector</i></p>	<p>7 Encapsulated Coil:</p> <p>EC: Included</p> <p><i>Leave blank if not required</i></p>	<p>8 Mount: ⁴</p> <p>101: Mounting Ring</p> <p>126: Nikon F Mount (Male)</p> <p><i>Leave blank if not required</i></p>

² Other blade coating options may be available by special order.

³ Input side only; Teflon® coating is on opposite side to protect shutter blade surface. Light source must be input to the reflective side only.

⁴ Mounts are only compatible if #3 housing is optioned as well.

Electronic Sync.

The synchronization system for CS45 shutter devices incorporates a small magnet mounted to the driving mechanism and a Hall Effect sensor. When the device achieves approximately 80% of full open, the magnet causes the Hall effect sensor to change state, producing a signal to indicate that the shutter has switched to the active state. Shown is the CS45 series shutter schematic which incorporates this electronic synchronization system. **There is no connection to the designated synchronization pins when an electronic sync. is omitted.**

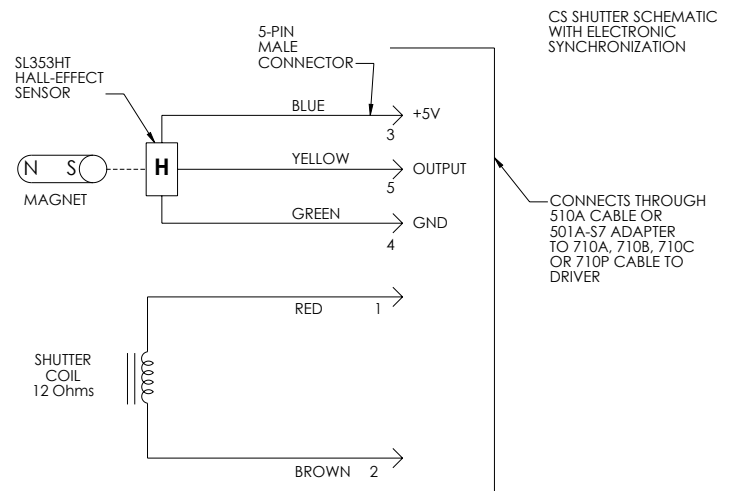

Uniblitz® CS45 Technical Drawings

Un-Housed

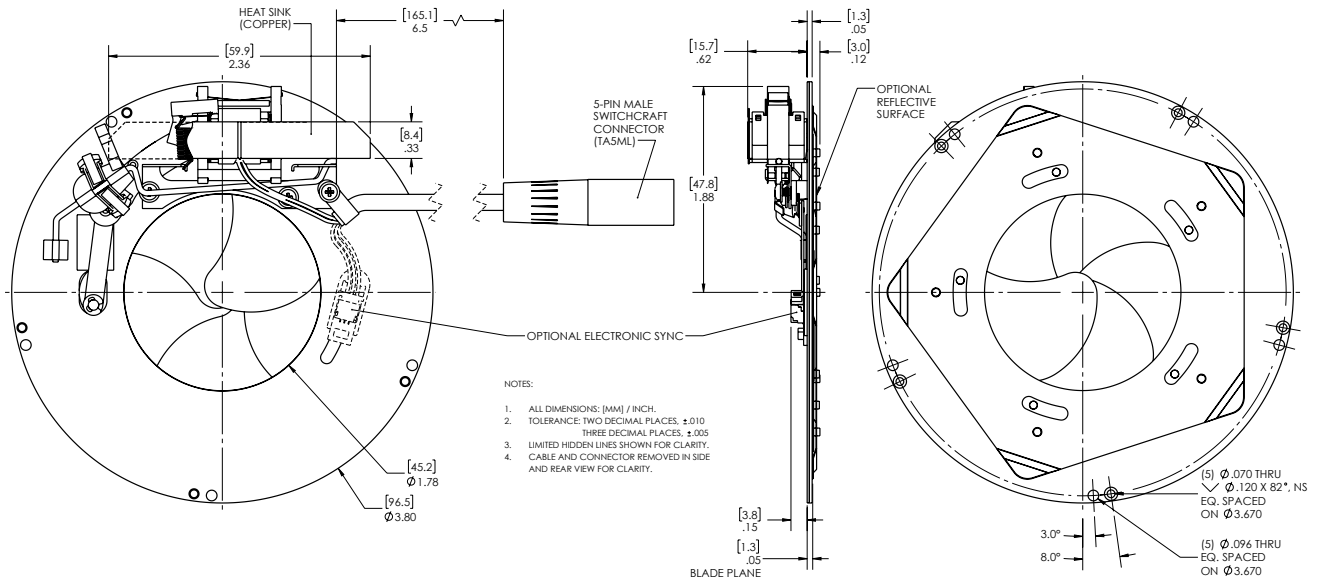

Housed / Connector Layout

