

Uniblitz® CS65

65mm Uni-Stable Optical Shutter

Overview

The Uniblitz CS65 has been designed to provide accurate, repeatable exposures for a wide variety of applications such as telescopy and aerospace. For 2022, the CS65 has been upgraded with dual actuators to significantly improve the shutter speed. The slim form-factor provides a 65mm aperture that can be inserted into a 5.00 inch diameter housing. It's available in a housed or un-housed configurations for OEM applications. Being uni-stable, the CS65 requires power to hold the blades in the open state.

Key Features

- Large 65mm aperture
- Dual-actuator design, configured for the [VCM-D1 Shutter Driver](#)
- **RoHS Compliant**
- Transfer time on opening:
38.0 milliseconds
- Total opening time:
45.0 milliseconds

¹ Actuators wired in parallel. Combined DCR is 12 Ω.

² Voltage level required across actuator coil when held in open position.

³ Dual hold voltage system included in VCM-D1 shutter driver.

Specifications

Primary Actuator Electrical Specifications ¹

Coil resistance	24 OHMS
Voltage to Open	+70 VDC
Hold Voltage (Nominal) ²	+7 VDC / +5 VDC ³ (continuous)

Secondary Actuator Electrical Specifications ¹

Coil resistance	24 OHMS
Voltage to Open	+70 VDC
Hold Voltage (Nominal) ²	+7 VDC / +5 VDC ³ (continuous)

Mechanical Specifications

Weight Unhoused	110.0 g
Weight Housed	370.0 g
Operating Temp.	0 - 80 °C
Max. Opening Bounce	15%
Max. Closing Bounce	5%
Max. Freq. of Operation ⁴	2 Hz / 5 Hz
Number of Shutter Blades	6

⁴ (Continuous/Burst) Continuous frequency rating specified at shutter's minimum exposure pulse. Burst frequency rating specified for four (4) seconds maximum with one (1) minute minimum between bursts.



Need Support? Please visit our website or email us at info@uniblitz.com.

Tel: +1 585-385-5930 | Fax: 585-385-6004 | 803 Linden Ave. Rochester, NY 14625

Updated 5/23 | Document Version 6.5 | ©2023 Vincent Associates

Shutter Timing Data

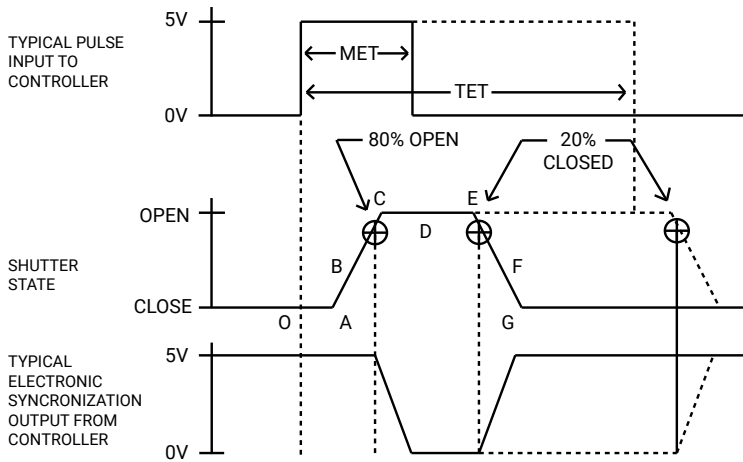

MET¹ and TET² for CS65

- **Minimum Exposure Time (MET):**
50.0 msec.³
- **Typical Exposure Time (TET):**
150.0 msec.³

CS65 ⁴ (w/ VCM-D1 and "T" blades) ⁵		Min. Exp. Time (msec.)		Typ. Exp. Time (msec.)	
Graph	Description	Typical	Max	Typical	Max
O - A	Delay time on opening after current is applied	7.0	8.0	7.0	8.0
A - C	Transfer time on opening	38.0	40.0	38.0	40.0
O - C	Total opening time	45.0	48.0	45.0	48.0
B - F	Minimum equivalent exposure time	50.5	54.5	160.0	163.5
C - E	Minimum dwell time (based on exposure pulse)	14.0	15.0	120.0	121.0
D - E	Delay time on closing after current is removed	9.0	13.0	15.0	19.0
E - G	Transfer time on closing	35.0	39.0	42.0	45.0
A - G	Total window time	87.0	94.0	200.0	206.0

¹ The minimum timing required to allow the shutter to fully open and then fully close.

² The exposure time provided to the driver where, as you increase the exposure pulse in one msec increments, the shutter output (or the A-G time) will change in one msec increments.

³ Due to non-linearity caused by damp and blade adjustment, exposure pulse selection between 50msec and 150msec may have some indeterminate typical and max values.

⁴ Individual timing segments may vary.

⁵ Under no circumstances should any type of lubricant be applied to the shutter blade area. Lubricating the shutter blades will likely slow the shutter down and may eventually render it inoperable.

Product Options

CS65H 2 3 4 5 6 - 7 - 8

Ex: CS65HS3T0-EC-102

<p>1 Shutter Series:</p> <p>CS65H</p>	<p>2 Driver Compatibility:</p> <p>S: Use with VCM-D1</p> <p>E: Use with V880, VED24, or D880C</p>	<p>3 Housing:</p> <p>1: Un-Housed</p> <p>3: #3 Housing</p>	<p>4 Blades:²</p> <p>T: Low Energy (Teflon®)</p> <p>ZM: High Energy (AlMgF2)³</p>
<p>5 Electronic Sync:</p> <p>0: Omitted</p> <p>1: Included</p>	<p>6 Connector:</p> <p>L: 18" Flying Leads</p> <p><i>Leave blank for 5-pin Switchcraft connector</i></p>	<p>7 Encapsulated Coil:</p> <p>EC: Included</p> <p><i>Leave blank if not required</i></p>	<p>8 Mount:⁴</p> <p>102: Mounting Ring</p> <p><i>Leave blank if not required</i></p>

² Other blade coating options may be available by special order.

³ Input side only; Teflon® coating is on opposite side to protect shutter blade surface. Light source must be input to the reflective side only.

⁴ Mounts are only compatible if #3 housing is optioned as well.

Electronic Sync.

The synchronization system for CS65 shutter devices incorporates a small magnet mounted to the driving mechanism and a Hall effect sensor. When the device achieves approximately 80% of full open, the magnet causes the Hall effect sensor to change state, producing a signal to indicate that the shutter has switched to the active state. Shown to the right is the CS65 series shutter schematic which incorporates this electronic synchronization system. There is no connection to the designated synchronization pins when an electronic sync. is omitted.

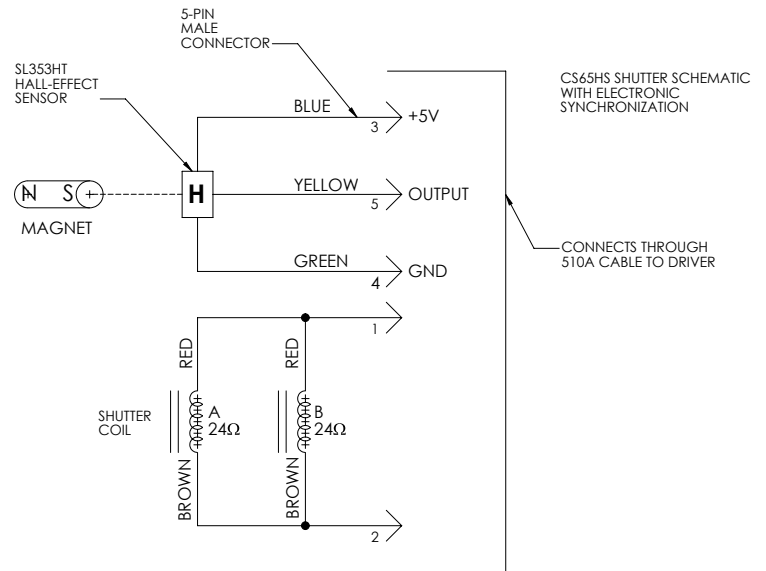

Uniblitz® CS65 Technical Drawings

Un-Housed

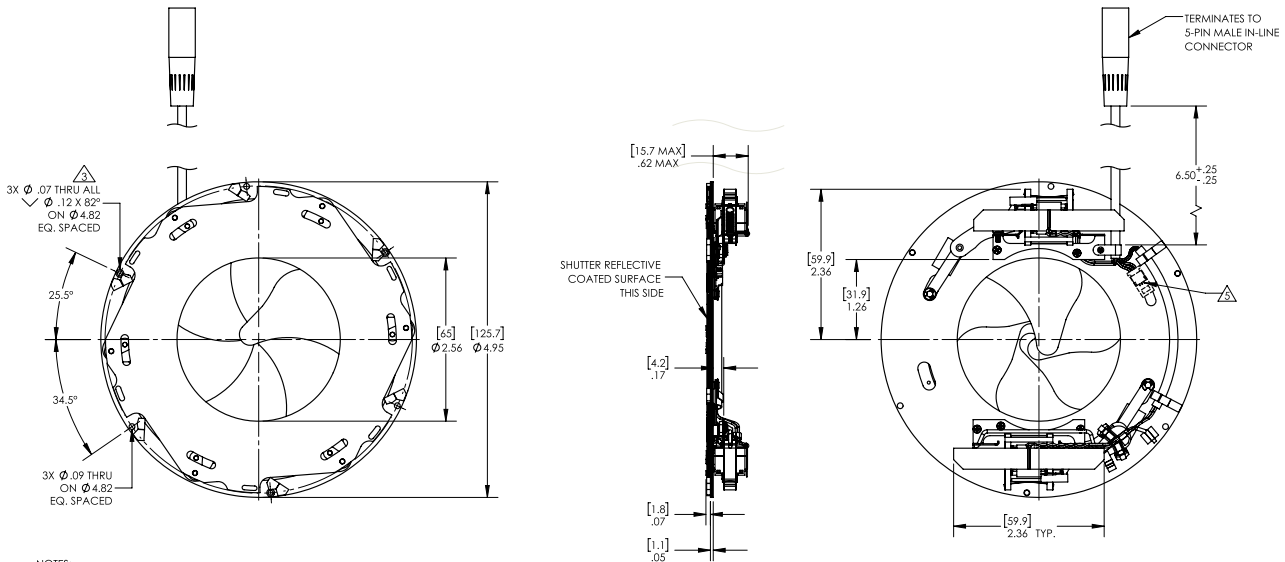

NOTES:

1. DIMENSIONS: [MM] INCH
2. WIRES OMITTED FOR CLARITY IN SIDE VIEW.
- △ RECOMMENDED MOUNTING HOLES.
4. ACTUATORS MUST BE WIRED IN PARALLEL FOR PROPER OPERATION.
- △ DASHED OUTLINE REPRESENTS OPTIONAL ELECTRONIC SYNCHRONIZATION SENSOR.

Housed / Connector Layout

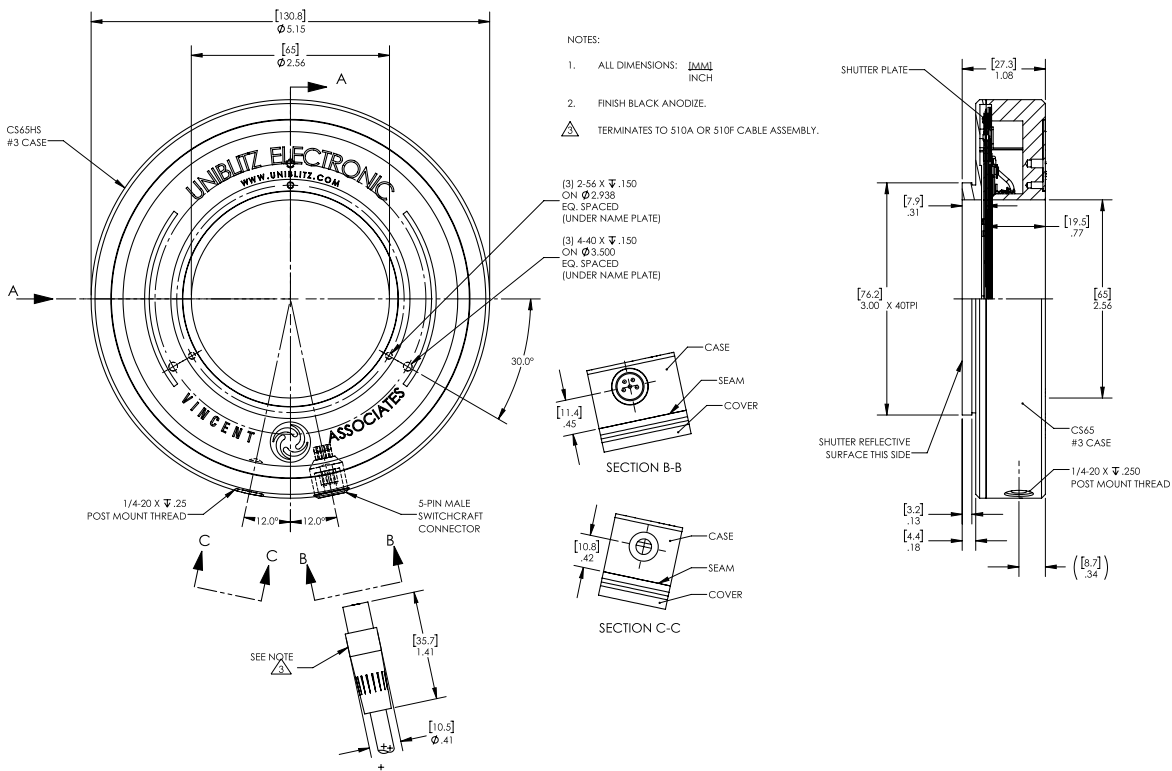

NOTES:

1. ALL DIMENSIONS: [MM] INCH
2. FINISH BLACK ANODIZE.
- △ TERMINATES TO 510A OR 510F CABLE ASSEMBLY.