

REVISIONS					
DATE	REV.	DESCRIPTION	DR	APPR.	CK
6/22/2004	A	REDRAWN IN SW	JCY	JFP	JFP

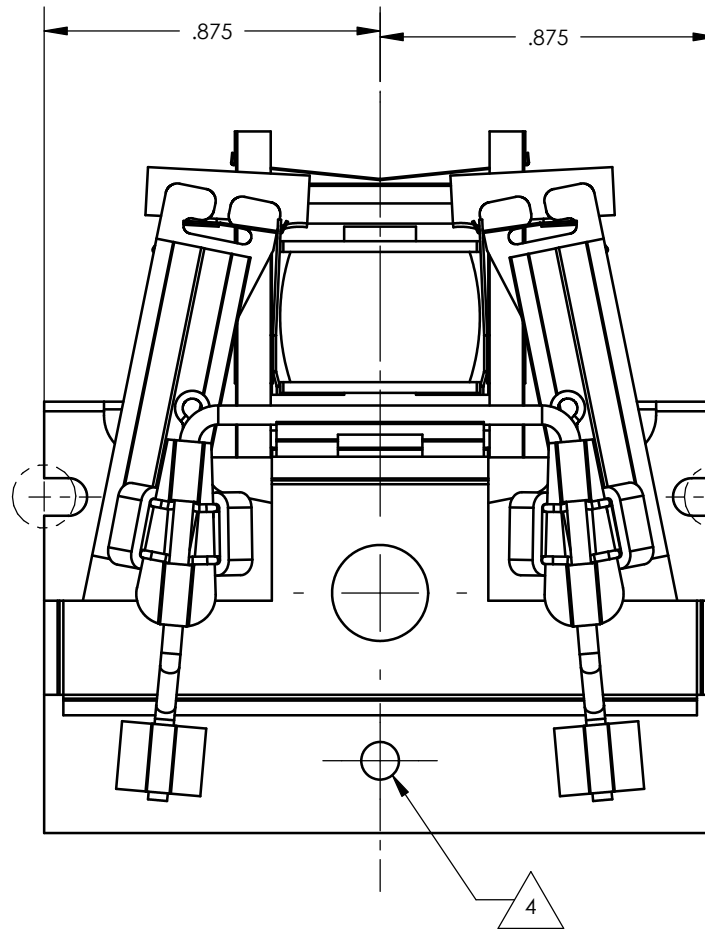

Ø.165
RECOMMENED
SCREW HEAD
DIAMETER

NOTES:

1. SHUTTER VIEW SHOWING SHUTTER AT OPENING POSITION.
2. SHUTTER VIEW SHOWING RECOMMENDED MOUNTING SCREW LOCATION.
3. USE SCREW (NO OTHER HARDWARD) WITH RECOMMENDED HEAD DIAMETER AT RECOMMENDED LOCATIONS TO ENSURE BLADES DO NO COME IN CONTACT WITH SCREW HEAD WHEN SHUTTER AT OPENING POSITION.

 4. ADDITIONAL MOUNTING HOLE LOCATION.

UNLESS OTHERWISE SPECIFIED: DIMENSIONS ARE IN INCHES TOLERANCES: FRACTIONAL $\pm 1/32$ ANGULAR: MACH $\pm 1^\circ$ BEND $\pm 1^\circ$ TWO PLACE DECIMAL $\pm .01$ THREE PLACE DECIMAL $\pm .005$	DRAWN	NAME	DATE	VINCENT ASSOCIATES Rochester, NY 14625 
	CHECKED	JFP	11/8/96	
PRIMARY FINISH: REMOVE ALL BURRS BREAK SHARP EDGES	ENG. APPR.	JFP	11/8/96	TITLE: LS6 MOUNTING RECOMMENDATION LAYOUT (OPEN)
SECONDARY FINISH: N/A	MATERIAL: N/A			SIZE A DWG. NO. L-0168 REV. A
DO NOT SCALE DRAWING	FILE NAME: Ls6 L-0168			SCALE: 1:2 WEIGHT: SHEET 1 OF 1