

# Uniblitz® CS65

65mm Uni-Stable Optical Shutter

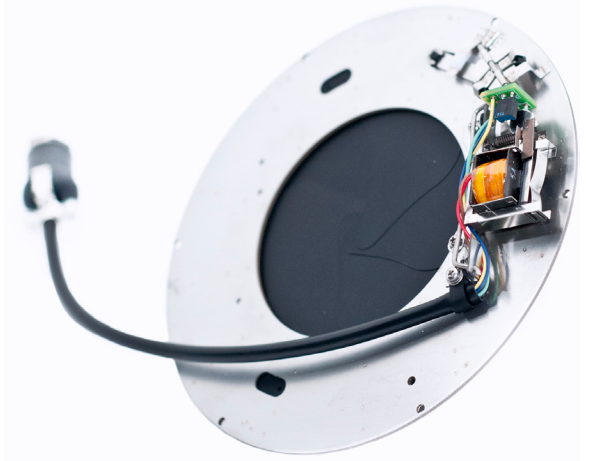

## Overview

The Uniblitz CS65 has been designed to provide accurate, repeatable exposures for a wide variety of applications such as telescopy and aerospace. The slim form-factor provides a large 65mm aperture that can be inserted into a 5.00 inch diameter housing. The CS65 is available in a housed or an un-housed configuration for OEM applications (or simply where spatial limitations are a consideration).

Uni-stable shutter devices, like the CS65, require power to hold the blades in the open state.

**Need Support?** Please [visit our website](#) or email us at [info@uniblitz.com](mailto:info@uniblitz.com).

Tel: 585-385-5930 | Toll-Free: 800-828-6972 | Fax: 585-385-6004 | 803 Linden Ave. Rochester, NY 14625

Updated 5/20 | Datasheet Version 5.4 | ©2020 Vincent Associates

## Key Features

- Large 65mm aperture
- Uni-stable operation
- 6-bladed design
- Slim form-factor
- **RoHS Compliant**
- Transfer time on opening:  
**45.0 milliseconds**
- Total opening time:  
**54.0 milliseconds**
- Configured for the **VCM-D1**  
**Shutter Driver**

# Product Options

CS65 2 3 4 5 6 - 7 - 8

Ex: CS65S3T0-EC-102

## 1 Shutter Series:

- **CS65**

## 2 Driver Compatibility:

- **S:** Use with VCM-D1 (Std.)
- **E:** Use with D880C or VED24

## 3 Housing:

- **1:** Un-Housed
- **3:** #3 Housing

## 4 Blade Coating:<sup>1</sup>

- **T:** Low Energy (Teflon®)
- **ZM:** High Energy (AlMgF2)<sup>2</sup>

## 5 Electronic Sync:

- **0:** Omitted
- **1:** Included

## 6 Connector:

- **L:** 18" flying leads (*Un-housed only*)
- Leave blank for 7-pin Wire Pro connector

## 7 Encapsulated Coil:

- **EC:** Included
- Leave blank if not required

## 8 Mount: (#3 housing only)

- **102:** Mounting ring
- Leave blank if not required

<sup>1</sup> Other blade coating options may be available by special order.

<sup>2</sup> Input side only; Teflon® coating is on opposite side to protect shutter blade surface. Light source must be input to the reflective side only.

# Shutter Timing

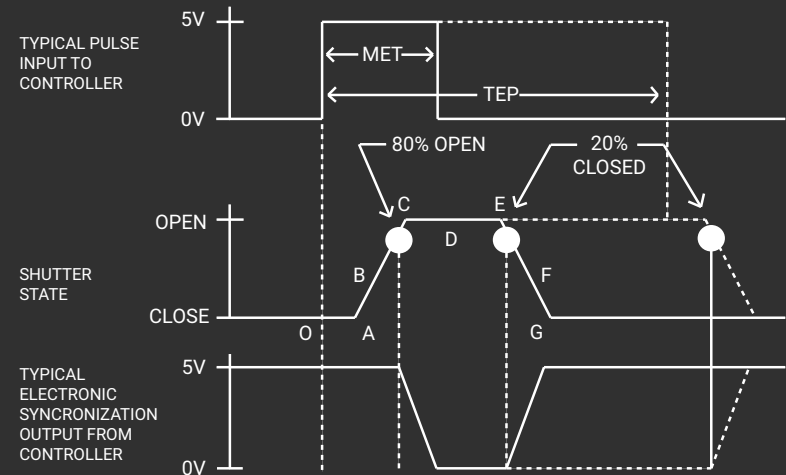

## CS65 (w/ VCM-D1 driver and Teflon® coated blades)

## Time (msec.)

O - A	Delay time on opening after current applied	9.0
A - C	Transfer time on opening	45.0
O - C	Total opening time	54.0
C - E	Min. dwell time with min. input pulse	22.0
B - F	Min. equivalent exp. time	70.0
E - G	Transfer time on closing	52.0
A - G	Total window time	119.0
MET	Min. exposure time	65.0
TEP	Typical exposure pulse	>75.0

# Technical Specifications

Coil Resistance	Voltage to Open	Hold Voltage (Nominal) <sup>1</sup>
12 Ω	+70 VDC	+7 VDC / +5 VDC <sup>2</sup>

<sup>1</sup> Voltage level required across actuator coil when held in the open position.

<sup>2</sup> Dual hold voltage system included in **VCM-D1 Driver**

<sup>3</sup> (Continuous/Burst) Continuous frequency rating specified at shutter's minimum exposure pulse. Burst frequency rating specified for four (4) seconds maximum with one (1) minute minimum between bursts.

Series	Weight (Unhoused)	Weight (Housed)	Operating Temp.	Max. Opening Bounce	Max. Closing Bounce	Max. Freq. of Operation <sup>3</sup>	Number of Shutter Blades
CS65	4.00 oz (0.11 kg)	13.20 oz (0.37 kg)	0 - 80 °C	15%	5%	2 Hz / 5 Hz	6

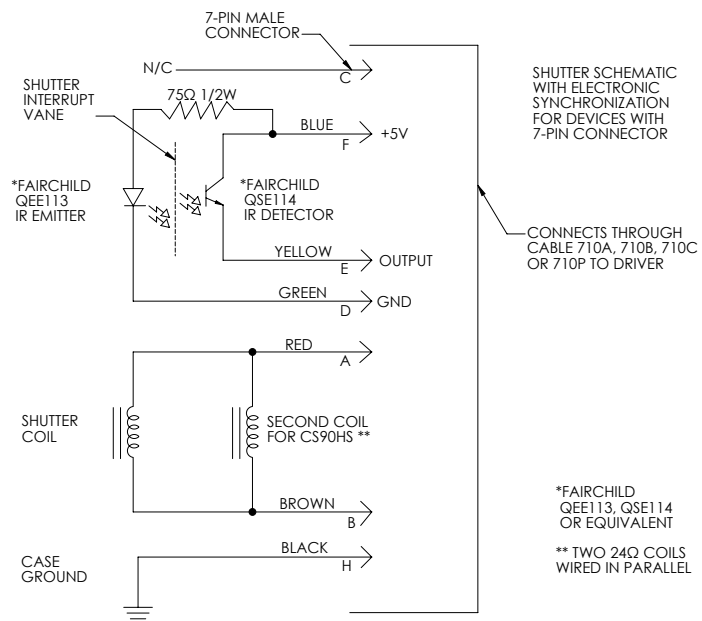

The electronic synchronization system provides a feedback signal (through the driver utilized) after the shutter transfers to the open state. The system incorporates an infrared emitting diode, an infrared sensitive detecting transistor, and an interrupting vane. The vane is attached to the shutter so as to block the light path between the emitter and detector in the closed position. When the shutter transfers to the 80% open position, the vane is removed from the infrared light path, allowing the emitter to switch the detector to the active state. For the CS65, this system uses a similar activation flag attached to the mechanism, which triggers a reflective emitter/detector device. **No connection to the designated synchronization pins when no electronic sync. is selected.**

# Technical Drawings - Un-housed CS65

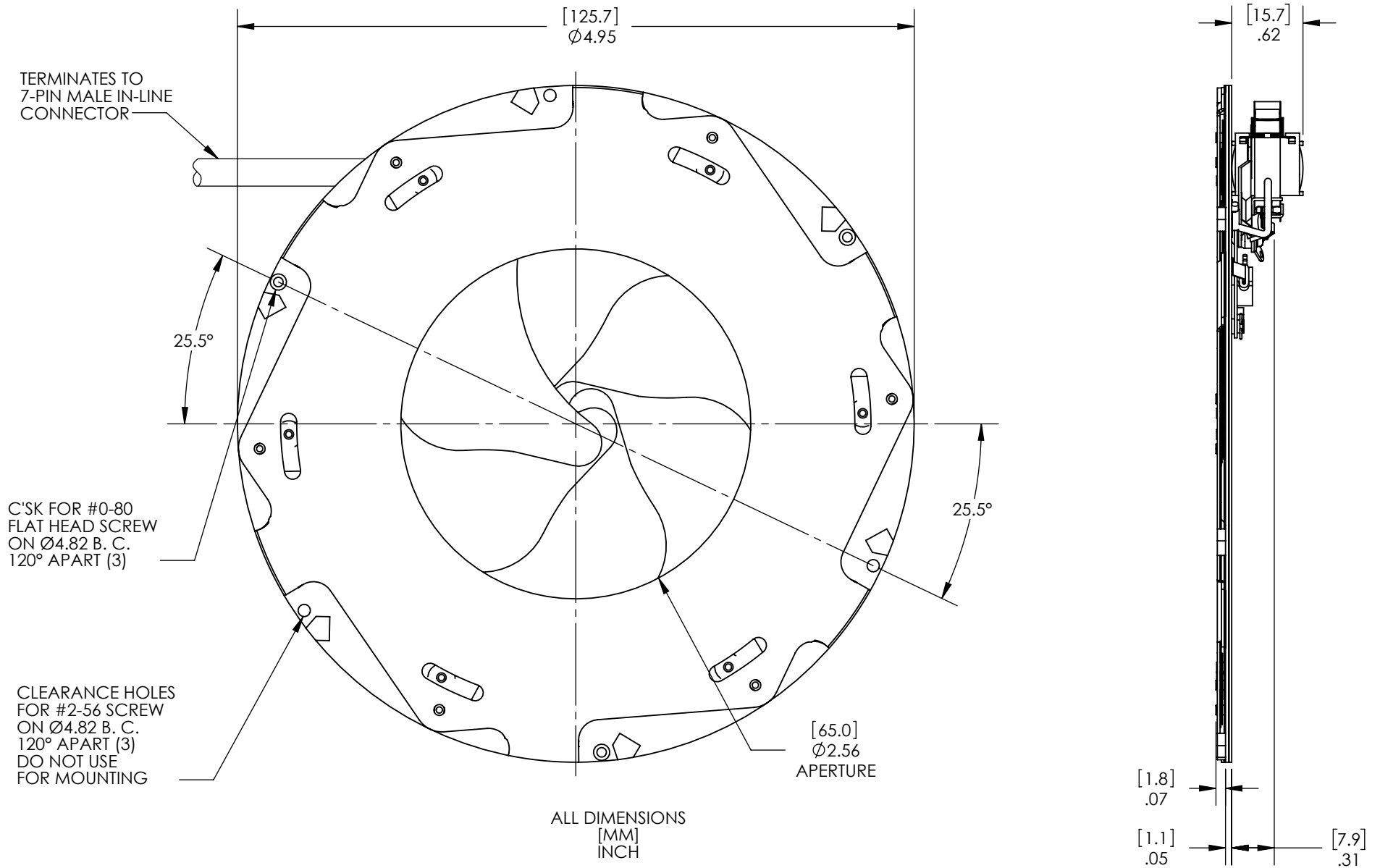

# Technical Drawings - Housed CS65

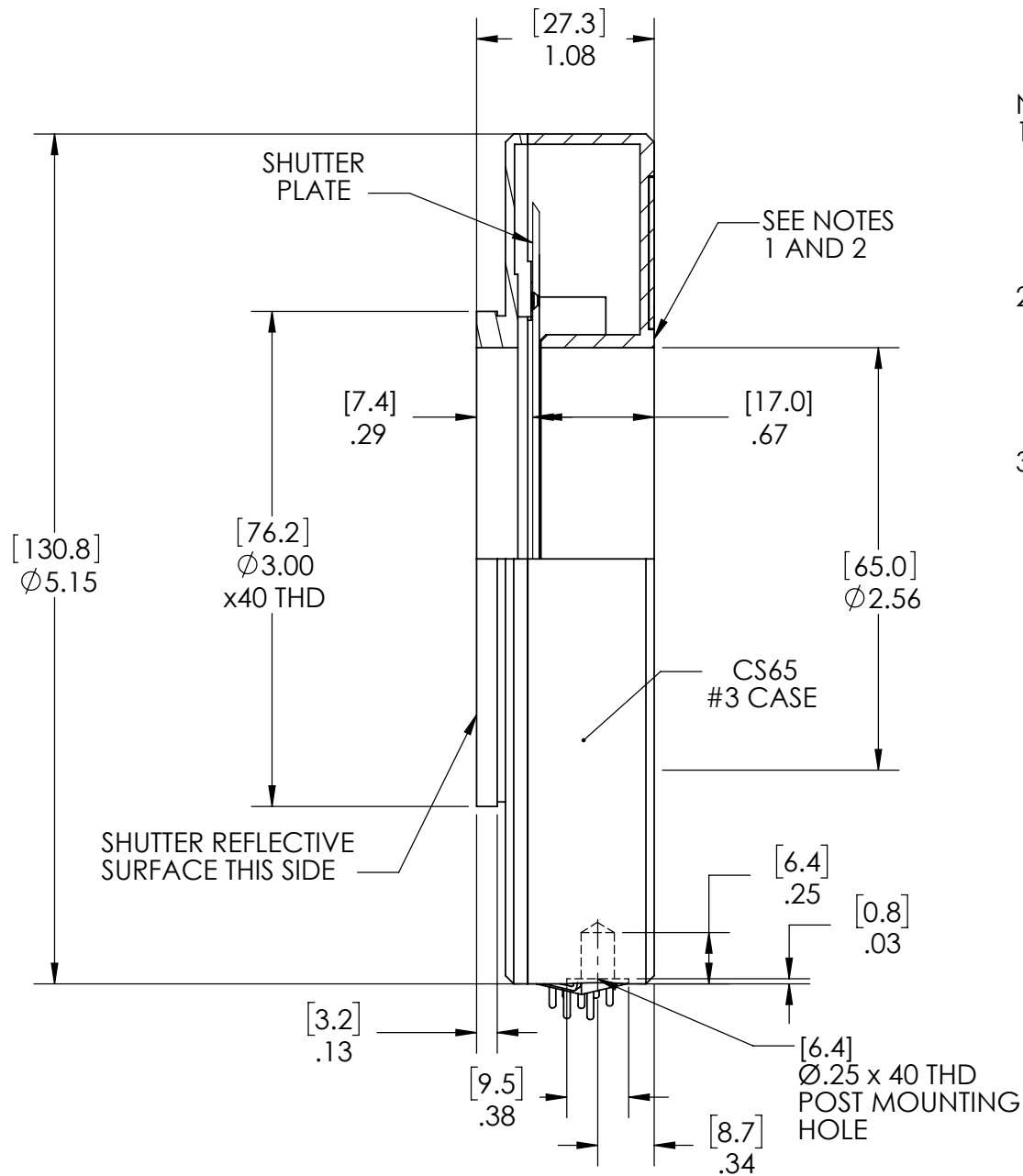

## NOTES:

1. (3) 2-56 MOUNTING HOLES ON A Ø2.938 BOLT CIRCLE 120° APART (UNDER NAME PLATE)
2. (3) 4-40 MOUNTING HOLES ON A Ø3.500 BOLT CIRCLE 120° APART (UNDER NAME PLATE)
3. ALL DIMENSIONS MAX.

[MM]  
INCH

# Technical Drawings - CS65 Connector Layout

