

VIEW B

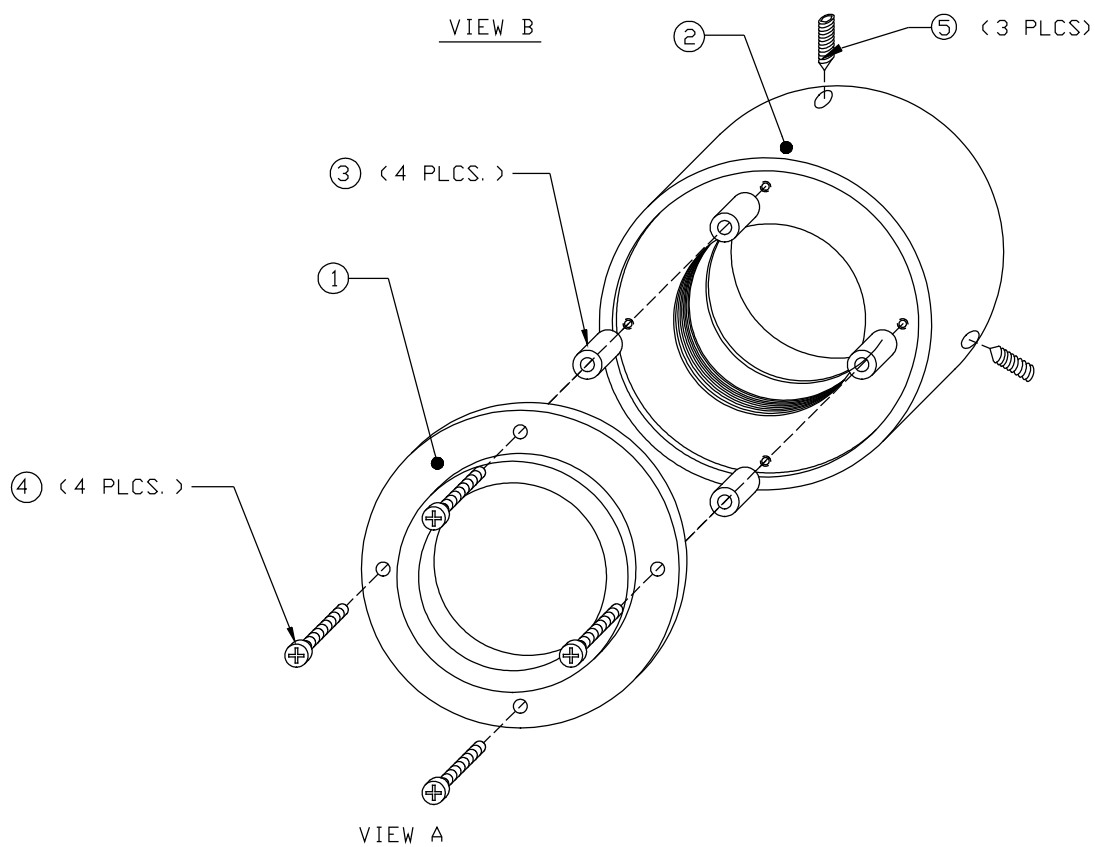

VIEW A

NOTES:

1. ASSEMBLE THE #100 MOUNTING RING ① TO THE #20 REAR ADAPTER ② WITH SCREWS ④ AND SPACERS ③ AS SHOWN IN VIEW A.
2. NOTE FINAL ASSEMBLY SHOWN IN VIEW B.
3. BEFORE INSERTING SET SCREWS ⑤ APPLY LOCKTITE THREAD LOCKER 222.

NEXT ASSEMBLY #9012-571

ITEM	PART NO.	DESCRIPTION	QTY.
5	20-0155	6-32 x 3/8 SOCKET SET CONE PT.	3
4	20-0165	4-40 x 1/2 PAN HD. SCREW	4
3	21-0019	1/4 x 1/4 #4 ROUND SPACER	4
2	9003-210	#20 REAR ADAPTER	1
1	9003-025	#100 MOUNTING RING	1

PARTS LIST

FINISH: N/A	MATERIAL: N/A	 VINCENT ASSOCIATES Rochester, NY 14607	
TOLERANCES:		TITLE: #20 ZEISS REAR ADAPTER ASSY.	DRAWN: <i>H. Yan</i>
DECIMAL: xx ± .01 xxx ± .005	REMOVE ALL BURRS	FILE NAME: 20_Rasy.dwg	DATE: 4/16/99
FRACTIONAL: ± 1/32	BREAK ALL SHARP EDGES	APPROVED BY: <i>J.P.</i>	SCALE: NONE
ANGULAR: ± 1°		SHEET 1 OF 1	REV. DRAWING NO. 9012-570