

VIEW B

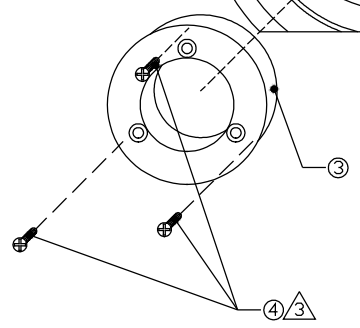
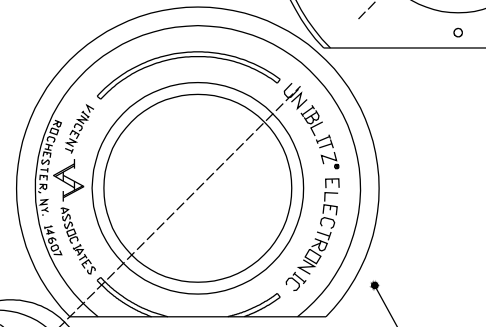
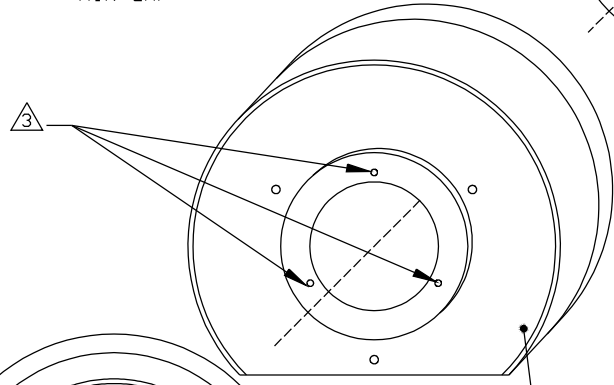
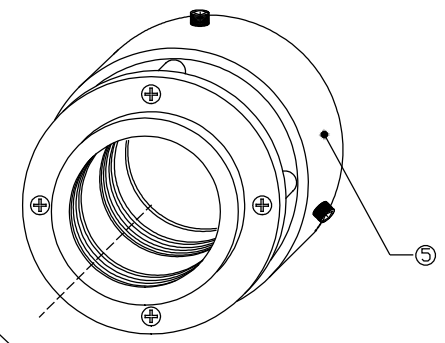
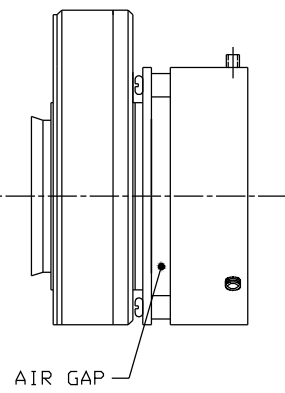

VIEW A

NOTES:

- ASSEMBLE PER PARTS LIST. CHOOSE THE PROPER CASE ALONG WITH THE CORRESPONDING NAME PLATE. VS25 CASE AND NAME PLATE SHOWN IN THIS DRAWING.
- PRESS NAME PLATE (2), ONTO THE CASE, (1).
- USING (3) 2-56 SCREWS (4), ATTACH #20 FRONT MOUNT (3), TO THE FRONT OF THE SHUTTER CASE (1).
- SCREW THE REAR ADAPTER ASSEMBLY (5) TO THE BACK OF THE CASE (1), TIGHTEN SECURELY.
- FINAL ASSEMBLY SHOWN IN VIEW B.
- NAME PLATE PART NO:
VS14/25: #9003-144, LS: #9003-145
CASE PART NO:
VS14/25: #9003-016, LS: #9003-013.

ITEM	PART NO.	DESCRIPTION	QTY.
5	9012-570	#20 REAR ADAPTER ASSEMBLY	1
4	20-0104	SCREW 2-56 x 5/16 BLK. OXIDE	3
3	9003-211	#20 FRONT MOUNT ADAPTER	1
2	SEE NOTE 6	NAME PLATE (VS14/25, OR LS)	1
1	SEE NOTE 6	#21 SHUTTER CASE (VS14/25, OR LS)	1
ITEM	PART NO.	DESCRIPTION	QTY.

PARTS LIST

FINISH: N/A	MATERIAL: N/A	 VINCENT ASSOCIATES Rochester, NY 14607		TITLE: #20 ZEISS MOUNT ASSEMBLY	DRAWN: <i>W. V. 4/97</i>
TOLERANCES: (EXCEPT AS NOTED) DECIMAL: XX ± .01 XXX ± .005 FRACTIONAL: ± 1/32 ANGULAR: ± 1°	REMOVE ALL BURRS	FILE NAME: 20_Finosy.dwg	APPROVED BY: 7/6/99 <i>BJP.</i>	SCALE: NONE	DATE: 4/16/99
	BREAK SHARP EDGES	SHEET 1 OF 1	SIZE C	REV.	DRAWING NO. 9012-571