

RS20B 20mm Bi-Stable Shutter System

Features



- A new device based on proven technology, the RS20 is a bi-stable shutter system containing all drive components within the shutter housing.
- Rectangular aperture (20mm diagonal)
- Control only requires a supply voltage (5-12VDC) and open/close pulses (TTL)
- Can be utilized as a development platform with scalability to custom sizes and customer unique specifications.

Applications

- Non-uniformity correction applications
- Spectrometry
- High Speed Digital Imaging Systems



Fig. 1 RS20 20mm Bi-Stable Shutter

Timing

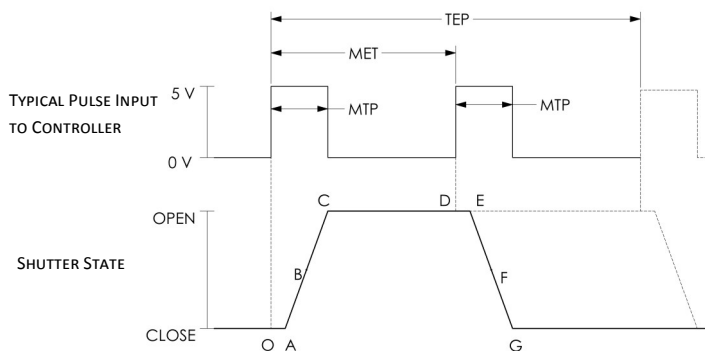

Fig. 2

RS20B		Time (msec.) ¹
O-A:	Delay time on opening after current is applied	8.2
A-C:	Transfer time on opening	10.6
D-E:	Delay time on closing after current is applied	11.4
E-G:	Transfer time on closing	9.8
MTP	Minimum Trigger Pulse	25
MET	Minimum exposure time	26
TEP	Typical Exposure Pulse	100

¹This chart lists preliminary timing values with a 12 VDC supply voltage, connected to the driver IC: ON Semi LV8548MC. For timing with other supply voltages contact Vincent Associates.

Electrical

COIL RESISTANCE	SUPPLY VOLTAGE ²	TRIGGER PULSE TO OPEN ²	TRIGGER PULSE TO CLOSE ²	OPEN/CLOSE PULSE WIDTH (msec.) ²
8 OHMS	+5-12VDC	+5V Active High TTL	+5V Active High TTL	25.0

² See Fig. 3 for connector pin-outs. Standard configuration RS20B is a RoHS compliant device.

Mechanical

SHUTTER	WEIGHT UNCASSED	OPERATING TEMP. (DEGREES)	MAX. FREQUENCY OF OPERATION ²	NUMBER OF SHUTTER BLADES
RS20B	0.32 oz (9.1g)	-10 to +65° C	10 Hz	1

Measurements are taken in free air, 25°C ambient with a 12V supply voltage. For additional information on maximum sustained frequencies obtainable with different drive voltages, please contact one of our technical representatives.

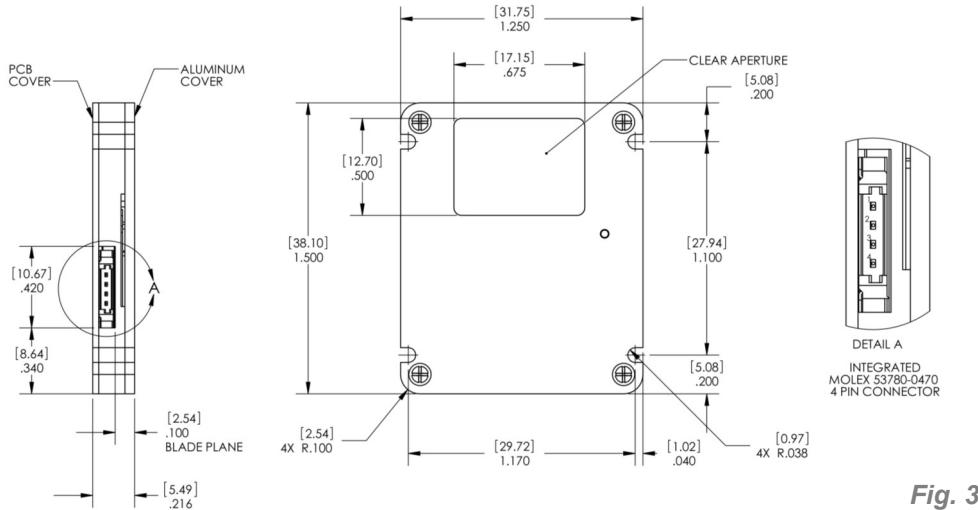

Fig. 3

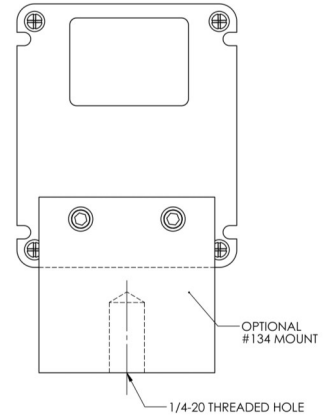
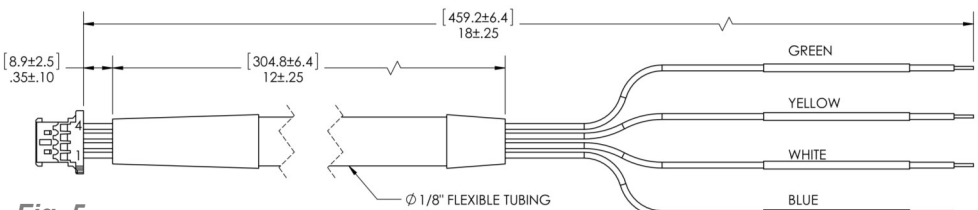

Fig. 4

Optional #134 mount will allow for mounting RS20B to a standard 1/4-20 threaded post.

Harness



PIN	COLOR	FUNCTION
1	BLUE	+5-12VDC
2	WHITE	OPEN PULSE
3	YELLOW	CLOSE PULSE
4	GREEN	GROUND

Fig. 5

This 18" 401P harness will be included with the device.

Optical

The standard shutter blade is made of a carbon impregnated PET (polyethylene terephthalate) base material that is ideally suited for optics applications requiring high emissivity and optical density. See uniblitz.com for specific emissivity data. Because the material is a thermoplastic polymer, maximum surface temperature should not exceed 100°C. For applications requiring higher heat resistance please contact a technical representative for alternative blade materials.

Product Options

Example Part Number: RS20B1C0-134

Part Number: **RS20B1C0** -

<p>1 Aperture Size\Type: RS20B1C0: 20mm</p>	<p>2 Mount: 134: #134 mount included ♦ Leave blank to omit mount</p>
--	---