

REVISIONS					
DATE	REV.	DESCRIPTION	DR	APPR.	CK
2/9/2012	A	INITIAL RELEASE	HY	JJP	JJP
5/2/2013	B	1.000 DIM WAS .750	DJF	JJP	JJP

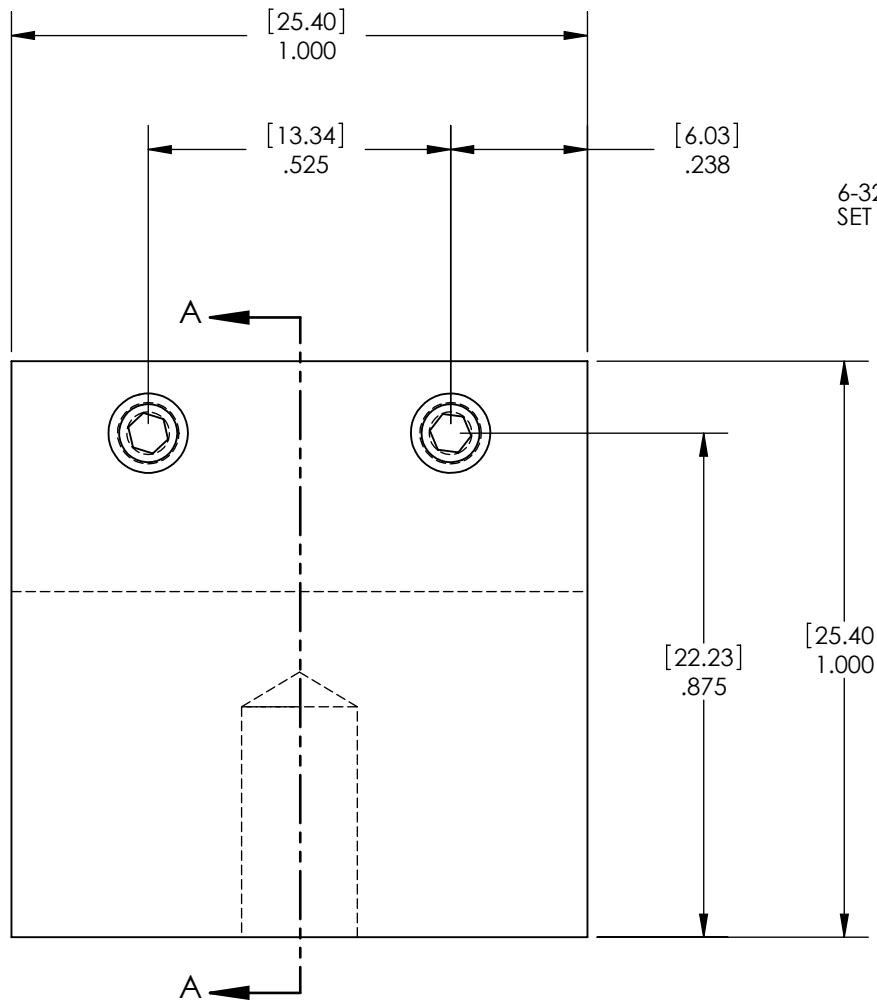

6-32 UNC NYLON TIPPED SET SCREWS (2)

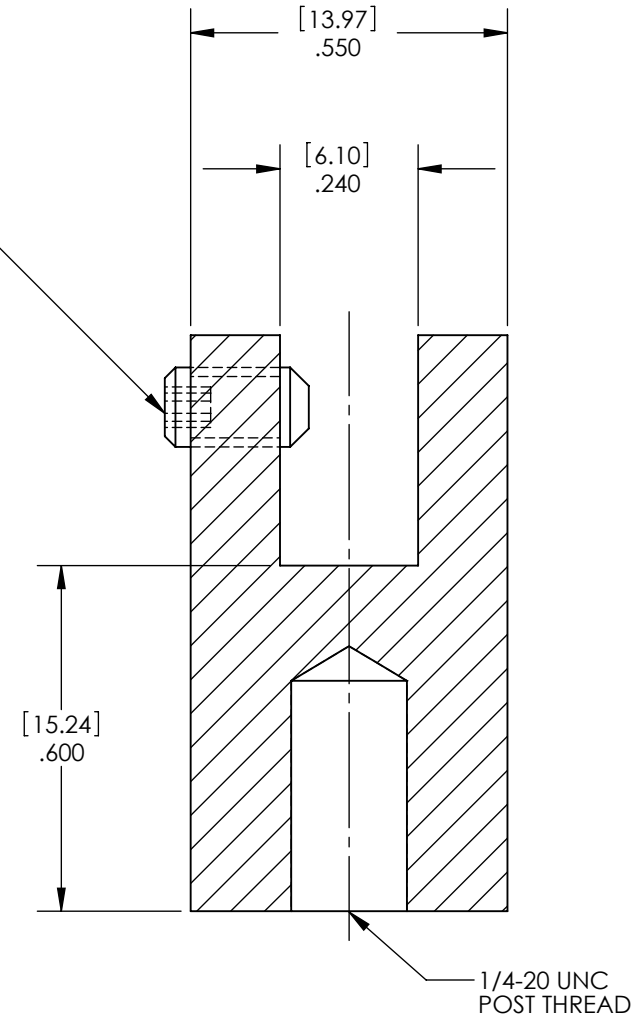

1/4-20 UNC POST THREAD

ALL DIMENSIONS

[MM]
INCH

UNLESS OTHERWISE SPECIFIED:		NAME	DATE	VINCENT ASSOCIATES Rochester, NY 14625	
DIMENSIONS ARE IN INCHES		DRAWN	2/9/12	TITLE: #134 POST MOUNT ADAPTER FOR NS15/25 LAYOUT	
TOLERANCES:		CHECKED	2/20/12		
FRACTIONAL ± 1/32		ENG. APPR.	2/20/12	SIZE A DWG. NO. L-0644	
ANGULAR: MACH ± 1° BEND ± 1°		MATERIAL: N/A			
TWO PLACE DECIMAL ± .01		Project: Mounts		REV. B	
THREE PLACE DECIMAL ± .005					
PRIMARY FINISH: REMOVE ALL BURRS BREAK SHARP EDGES		MODEL NAME: NS15_25 Post Mount DRAWING NAME: #134 post mount adapter		WEIGHT:	
SECONDARY FINISH: N/A		DO NOT SCALE DRAWING		SHEET 1 OF 1	