

# Uniblitz® DSS25B

25mm Bi-Stable Optical Shutter



## Overview

The Uniblitz DSS25B is a 25mm-aperture bi-stable optical shutter that has eliminated the external protruding actuator and contains no other interfering components. This makes the DSS25B an extremely low-profile device that is capable of fitting into very tight spaces. Additionally, the device's flat mounting surfaces make for its easy integration into virtually any system.

Bi-stable shutter devices, like the DSS25B, require no power to hold the blades in either the open or closed state.

**Need Support?** Please [visit our website](#) or email us at [info@uniblitz.com](mailto:info@uniblitz.com).

Tel: 585-385-5930 | Toll-Free: 800-828-6972 | Fax: 585-385-6004 | 803 Linden Ave. Rochester, NY 14625

Updated 12/17 | Datasheet Version 5.3 | ©2017 Vincent Associates

## Key Features

- 25mm aperture
- Bi-stable operation
- Only two unique moving parts
- Slim, low-profile form-factor
- **RoHS Compliant**
- Transfer time on opening:  
**12.6 milliseconds**
- Total opening time:  
**25.8 milliseconds**
- Configured for the **VED24**  
**Shutter Driver**

# Product Options

DSS25B 2 3 4 5

Ex: DSS25B1T0L

## 1 Shutter Series:

- **DSS25B**

## 2 Housing:

- **1**: Un-housed

## 3 Blade Coating: <sup>1</sup>

- **T**: Low Energy (Teflon®)
- **ZM**: High Energy (AlMgF<sub>2</sub>) <sup>2</sup>

## 4 Electronic Sync:

- **0**: Omitted

## 5 Connector: <sup>3</sup>

- **L**: 2 wire bare leads attached to a 4" flex connector
- Leave blank for 2-pin JST connector with 4" flex harness

<sup>1</sup> Other blade coating options may be available by special order.

<sup>2</sup> Input side only; Teflon® coating is on opposite side to protect shutter blade surface. Light source must be input to the reflective side only.

<sup>3</sup> Custom terminations are available. Please contact a technical representative for more information.

# Shutter Timing

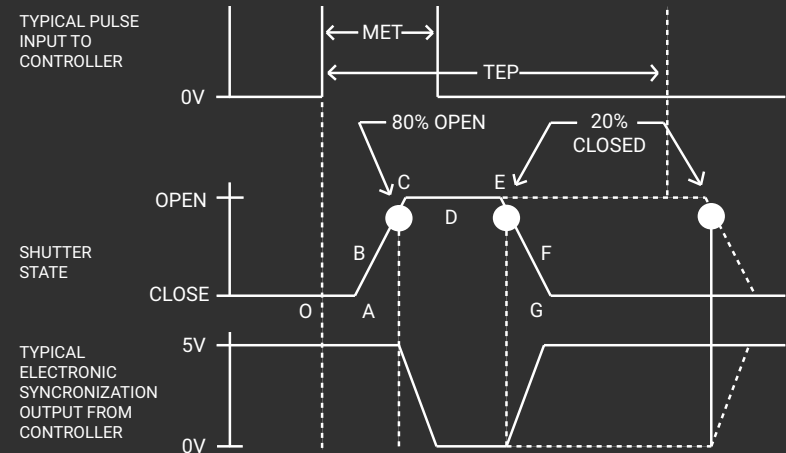

DSS25B (w/ ED12DSS and Teflon® coated blades)		Time (msec.)
O - A	Delay time on opening after current applied	13.2
A - C	Transfer time on opening	12.6
O - C	Total opening time	25.8
C - E	Min. dwell time with min. input pulse	23.2
B - F	Min. equivalent exp. time	36.6
D - E	Delay time on closing after current applied	14.0
E - G	Transfer time on closing	14.0
A - G	Total window time	50.8
MET	Min. exposure time	35.0
TEP	Typical exposure pulse	>35.0

# Technical Specifications

Coil Resistance	Voltage to Open	Hold Voltage
7.5 $\Omega$	+10.7 VDC <sup>1</sup>	N/A

<sup>1</sup> Peak voltage as provided by the **VED24 Driver**

<sup>2</sup> (Continuous/Burst) Continuous frequency rating specified at shutter's minimum exposure pulse. Burst frequency rating specified for four (4) seconds maximum with one (1) minute minimum between bursts.

Series	Weight	Operating Temp.	Max. Opening Bounce	Max. Closing Bounce	Max. Freq. of Operation <sup>2</sup>	Number of Shutter Blades
DSS25B	0.73 oz (20.70 g)	-10 - 65 °C	15%	5%	5 Hz / 10 Hz	5

# Technical Drawings - DSS25B

