

INSTRUCTION MANUAL
for

UNIBLITZ[®]
MODEL DM412
SHUTTER DRIVE MODULE

VINCENT ASSOCIATES
803 LINDEN AVE.
ROCHESTER, NEW YORK 14625
SERVICE/ORDERS (800) 828-6972
In NY State (585) 385-5930
Fax (585) 385-6004

INTRODUCTION

The **DM412 Drive Module** interfaces the smallest aperture shutter in the **UNIBLITZ**[®] line, the **UHS1T2 High Speed Shutter**, to the **VMM-D1** or **VMM-T1** shutter driver units. Operation of the **DM412** is simple and straightforward. All activate functions are supplied through the **VMM-D1** or **VMM-T1** shutter drivers. The only control integral to the **DM412** is the **NORMHIGH** switch, which allows “on-the-fly” selection between the normal (**NORM**) and the (**HIGH**) speed modes. The **CONTROL BNC** allows TTL (active low) or remote switch (**710R**) to electronically select the normal and high-speed modes, providing greater flexibility.

MAINTENANCE

Although the stability of the timing and drive voltage is assured and calibrated prior to shipment, it may become necessary to make some minor adjustments to the operating systems of the **DM412** and the **VMM-T1** or **VMM-D1** over time.

It is highly recommended that if you suspect a problem with your unit that it be returned to the factory for proper adjustments and calibration. The units' complicated circuitry will be damaged and/or not function as specified if adjusted improperly.

Proper care and maintenance of the unit should be taken as with any electronic instrument.

WARRANTY

Great care has been taken to ensure that our products are free from defect when shipped. Defective units will be replaced or repaired at no charge, excepting transportation charges, if returned within 90 days from the date of shipment. Vincent Associates will consider the return of unused equipment if returned within 30 days from the date of shipment subject to a 20% restocking charge. This offer does not apply to used or damaged equipment.

SPECIFICATIONS

Shutter Drive Output (9-Pin Female)	Continuously variable frequency o exposures from DC to the shutter's maximum value. Maximum peak pulse power 325W, pulse voltage 65VDC, and pulse current 5A. The DM412 contains two internal drive circuits with the same power spec.
Controller Input (7-Pin Male)	+65VDC high voltage and +6.75 VDC low voltage power input from VMM-D1 or VMM-T1 controller. Input trigger control and synchronization return amplifier is also provided from the VMM-D1 or VMM-T1 controller.
Control Input (BNC)	Input impedance 10K ohms. Active low. Source current 500 μ A. Minimum delay time required to ensure mode switching prior to shutter activation 10msec.
Power Indicator	Red LED indicates when power is applied.
Power Requirements	Power provided from VMM-D1 or VMM-T1 Controller. See Controller Input specifications.
Fuse Requirements	5x20mm 800mA slow blow fuse for shutter actuator coil protection. Two required, one for each shutter coil.
Size (HWD)	1.718" (43.63mm) x 3.558" (90.37mm) x 3.180 (80.77mm) with black textured finish. See dwg. #L-0172.
Cables (included)	#910C - interconnect cable for UHS1T2 High Speed Shutter. #702C - interconnect cable for DM412 Shutter Drive Module.
Cable (optional)	#710R - remote trigger cable.

DM412 FRONT AND REAR PANEL OPERATOR CONTROLS DESCRIPTION (Refer to Drawing #L-0173)

1. **CONTROL INPUT.** BNC active low input. Electrically switches the **DM412** between the **HIGH** and **NORMAL** speed modes. A low level input places the unit into the **NORMAL** speed mode. A high level places the unit back to the **HIGH** speed mode.
2. **NORM/HIGH Switch.** Allows manual switching between the **HIGH** and **NORMAL** speed modes.
3. **POWER Indicator.**
4. **SHUTTER.** **DM412** 9-Pin female connector to mate with 9-Pin male connector of the 10' shutter interconnect cable provided with the control.
5. **CONTROLLER.** **DM412** 7-Pin male connector to mate with 7-Pin female connector of the 10' interconnect cable provided with the **VMM-D1** or **VMM-T1** controller. This cable provides power and control for the **DM412** control unit.
6. **FUSE B.** Replace with 5x20mm 800mA slow blow fuse.
7. **FUSE A.** Replace with 5x20mm 800mA slow blow fuse.

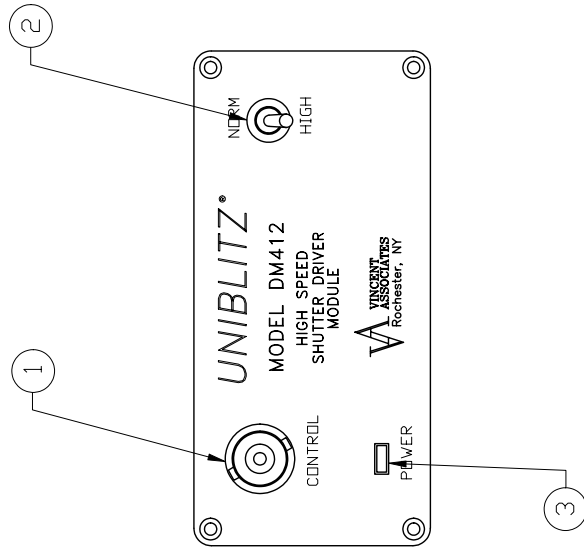

DM412 FRONT PANEL

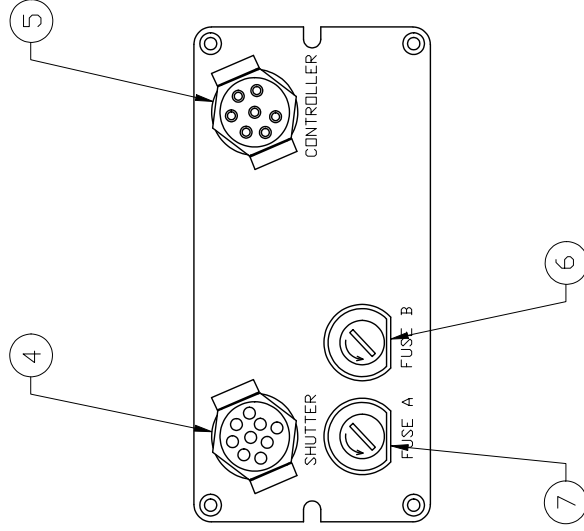

DM412 REAR PANEL

UNLESS SPECIFIED DIMENSIONS IN INCHES DO NOT SCALE DRAWING	MATERIAL: N/A	VINCENT ASSOCIATES Rochester, NY 14625		DRAWN: <i>Kia A.</i>
		PRIMARY FINISH: REMOVE ALL BURRS BREAK SHARP EDGES	TITLE: DM412 PANEL LAYOUT	CHECK: NONE
TOLERANCES: (EXCEPT AS NOTED) DECIMAL: XX ± .01 XXX ± .005 FRACTIONAL: ± 1/32 ANGULAR: ± 1°	SECONDARY FINISH: N/A	FILE NAME: Dm412f_r.dwg	APPROVED BY: 12/7/95 <i>dsj</i>	DATE: 12/7/95 SCALE:
		SHEET 1 OF 1	SIZE A	REV.
		DRAWING NO. L-0173		

OPERATING INSTRUCTIONS

After unpacking unit, inspect for any defects. If upon inspection a problem is found, notify Vincent Associates immediately.

After initial inspection, the unit is ready for use. Please read the following operating instructions. Improper input/output connections to the unit may cause irreparable damage.

The **DM412** receives power from **VMM-D1** or **VMM-T1** driver. Connect the **DM412** as per drawing #L-0171. Follow the power up procedure as described in the **VMM-D1/VMM-T1** users manual. Once power is on, the **DM412 POWER** LED will illuminate. Place the **NORM/HIGH** switch in the **NORM** position. Place the **N.O./N.C.** switch (of the **VMM-D1** or **VMM-T1**) to the **N.O.** position. The shutter will open and remain open until either the **N.O./N.C.** switch is returned to the **N.C.** position or the **NORM/HIGH** switch is returned to the **HIGH** position. Note, the **SYNC** LED and the **SHUTTER** LED (of the **VMM-D1** or **VMM-T1**) will illuminate when the shutter goes to the open position to indicate the presence of a shutter activate signal and that the shutter has opened respectively.

In the **HIGH**-speed mode, a signal to the **VMM-D1** or **VMM-T1** will trigger the **UHS1T2** for 300 μ sec. only. The shutter *cannot* be held open in this mode. For example, with the **DM412** in the **HIGH** mode, switching the **N.O./N.C.** switch to the **N.O.** position the shutter will open for 300 μ sec. (typical A - G time). The **SHUTTER** LED of the **VMM-D1** or **VMM-T1** will illuminate, however, the **SYNC** LED will only flash indicating a high-speed exposure. Please note, the typical shutter timing for each of the modes respectively is enumerated in the attached **UHS1** data sheet.

When operating the **UHS1** shutter from a pulse source (through the **VMM-T1** or **VMM-D1**) the minimum pulse width, in the **NORM** mode, is 600 μ sec. If the input pulse width in this mode is set to less than 600 μ sec., the shutter response will be indeterminate. If the input pulse is greater than 600 μ sec., the shutter will be held open for the duration of the pulse and therefore, in this mode, is programmable. Please note, though the minimum input pulse in the **NORM** mode is 600 μ sec., the shutter response (A - G window time) will typically be 1.0msec (see **UHS1** data sheet for typical timing data). In the **HIGH** speed mode the shutter exposure is 300 μ sec (proper exposure pulses are derived within the **DM412**), regardless of the duration of the input pulses to the **VMM-D1** or **VMM-T1**. Therefore, the minimum input pulse or trigger width, input to the **VMM-D1** or **VMM-T1**, will be as enumerated in the **SPECIFICATIONS** section of the **VMM-D1** or **VMM-T1** manual.

Please review the Caution section on page #21 in the VMM-D1/VMM-T1 manual for information concerning fuse inspection and replacement.

The UHS1 can be operated as any typical shutter in the NORM speed mode. Therefore, the shutter can also be controlled via the RS-232 interface. Please review SYSTEMS OPERATIONS section on page #22 in the VMM-D1/VMM-T1 manual.

DATE	SYM	REVISION RECORD	AUTH	DR	CK
12/19/96	A	702C WAS 710C ADDED BNC TO CABLE UPDATED NOTE 1	LSJP	NA	
12/19/96	B	VMM-D1/VMM-T1 WAS D122/T132	LSJP	NA	

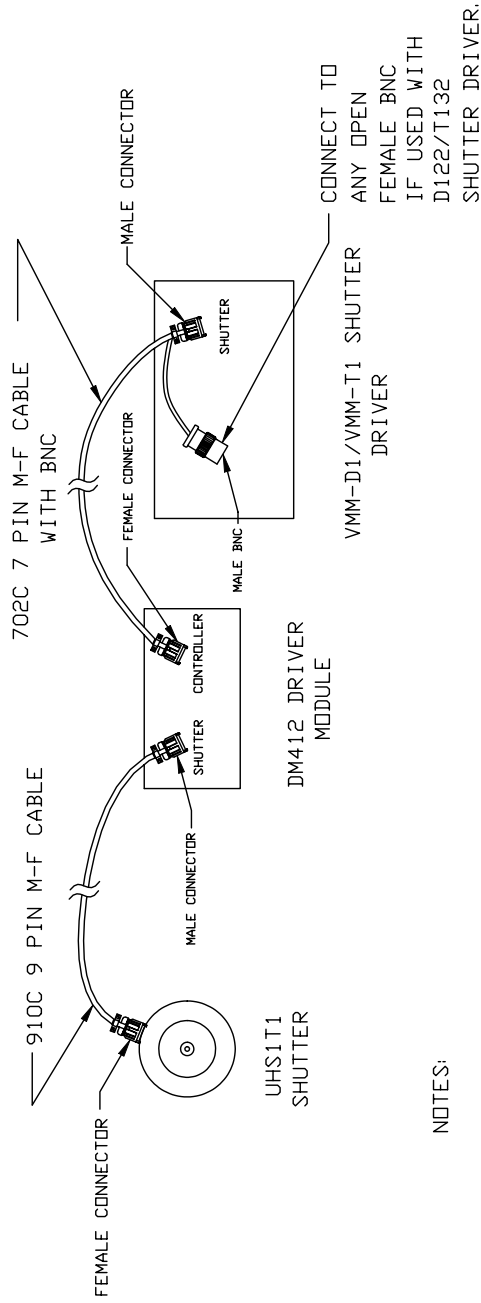

NOTES:

- 1 910C CABLE, 702C CABLE, UHS111, AND DM412 DRIVER MODULE INCLUDED IN ONE PACKAGE.
- 2 ADDITIONAL PANEL NOMENCLATURE OMITTED FOR CLARITY.

 UNLESS SPECIFIED DIMENSIONS IN INCHES DO NOT SCALE DRAWING	 VINCENT ASSOCIATES Rochester, NY 14625		DRAWN: <i>Sciba</i> A CHECK: NONE
	MATERIAL: N/A	TITLE: HIGHSPEED SHUTTER AND DRIVER HOOK-UP DIAGRAM	DATE: 12/7/95 SCALE:
TOLERANCES: (EXCEPT AS NOTED) DECIMAL: XX ± .01 FRACTIONAL: ± 1/32 ANGULAR: ± 1°	PRIMARY FINISH: REMOVE ALL BURRS BREAK SHARP EDGES	FILE NAME: APPROVED BY: Dm412con.DWG 12/7/95 LSJP	DRAWING NO. L-0171
SECONDARY FINISH: N/A	SHEET 1 OF 1	SIZE A REV. B	

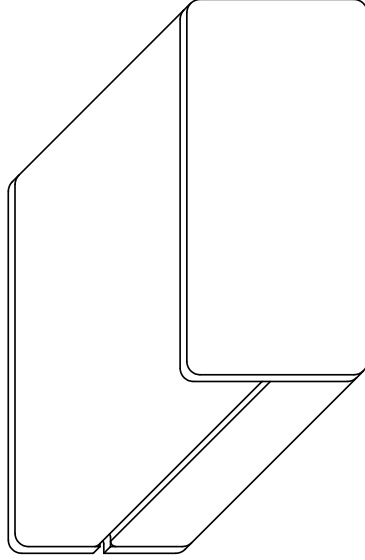
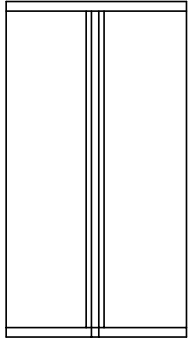
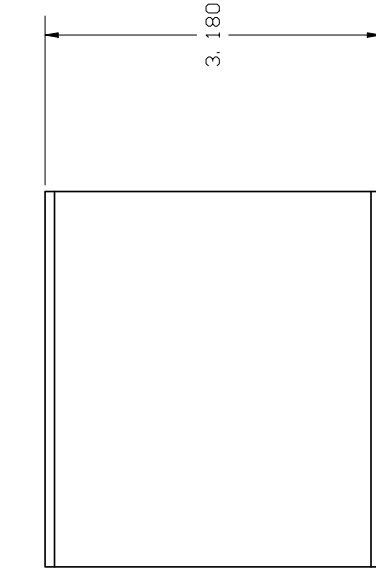
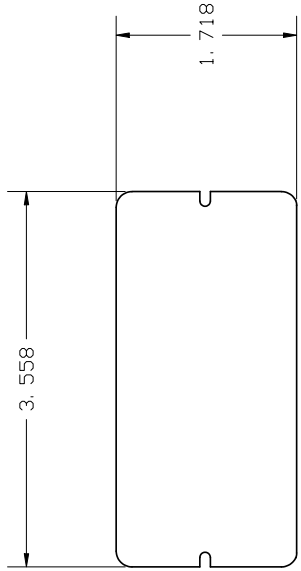

NOTES:

- 1 FRONT AND REAR PANEL CONTROLS OMITTED FOR CLARITY.

<p>UNLESS SPECIFIED DIMENSIONS IN INCHES DO NOT SCALE DRAWING</p>	<p>MATERIAL: N/A</p>	<p>VINCENT ASSOCIATES Rochester, NY 14625</p>		
		<p>TITLE: DM412 OVER-ALL CASE DRAWING</p>	<p>DRAWN: <i>JK</i> CHECK:</p>	
<p>TOLERANCES: (EXCEPT AS NOTED) DECIMAL: XX ± .01 FRACTIONAL: ± 1/32 ANGULAR: ± 1°</p>	<p>PRIMARY FINISH: REMOVE ALL BURRS BREAK SHARP EDGES</p>	<p>FILE NAME: DM412sq.L.dwg</p>	<p>APPROVED BY: <i>JJP</i></p>	<p>DATE: 12/7/95</p>
	<p>SECONDARY FINISH: N/A</p>	<p>SIZE B</p>	<p>REV. REV.</p>	<p>SCALE: NONE</p>
		<p>SHEET 1 OF 1</p>	<p>DRAWING NO. L-0172</p>	

FEATURES

- 1mm diameter aperture
- Fastest shutter in the **UNIBLITZ[®]** line of electro-programmable shutters.
- **300μsec.** total exposure time in the (HIGH) speed mode.
- **100μsec.** rise time.
- Activated by an electronic pulse through shutter driver module, the DM412, included.
- Exposure repetition rate continuously variable from DC-400Hz.
- Non-resonant design allows instantaneous changes in repetition rate and duty cycle in the normal (NORM) mode.
- No optical surface when open provides 100% transmittance

The **UHS1** supersedes the LS2 as the fastest shutter in Vincent's **UNIBLITZ** line. As with the LS series, the **UHS1** is specially suited for laser use, with applications including low level chopping, high speed switching, pulse gating and selection, and modulation to 400 Hz. In the high speed mode (HIGH) the **UHS1 produces a total exposure pulse of 300μsec!** This speed is unprecedented in Vincent type instrumentation shutters.

In the normal speed mode (NORM) the shutter is programmable, and activated by an electronic pulse generated by Vincent's drive module, the DM412. This module is included with the **UHS1**, and will interface with the D122 and T132 controllers. The DM412 converts the specialized shutter drive outputs into the voltage pulses necessary for proper operation of the **UHS1**.

DM412 Drive Module:

Operation of the DM412 is simple and straightforward. All activate functions are supplied through the D122 or T132 shutter drivers. The only controls integral to the DM412 are the NORM/HIGH switch which allows "on the fly" selections between the normal (NORM) and high (HIGH) speed modes. The CONTROL BNC allows TTL (active low) or remote switch (710R) to electronically select the normal and high speed modes, providing greater flexibility.

UNIBLITZ-HOW TO ORDER

Standard unit (DM412 included) **UHS1T2**

(Coated blades, future availability)

ELECTRICAL

COIL RES.	PULSE VOLTAGE TO OPEN	HOLD VOLT.
12 ohms*	+65VDC*	+5VDC*

* (each actuator)

MECHANICAL

WGT. CASED SHUTTER	OPERATING TEMP.	ABSOLUTE MAX. FREQUENCY OF OPERAT.	NUMBER BLADES
4.3 oz. (.121 Kg.)	0°C to +80°C	400Hz.	2

For dimension layout to the LS2/3/6 SHUTTER SPECIFICATIONS sheet FIGURE 1 and FIGURE 2.

TIMING

Typical timing values (msec.) using **UNIBLITZ** drive equipment and measured with **UNIBLITZ** shutters equipped with standard TEFLON[®] coated

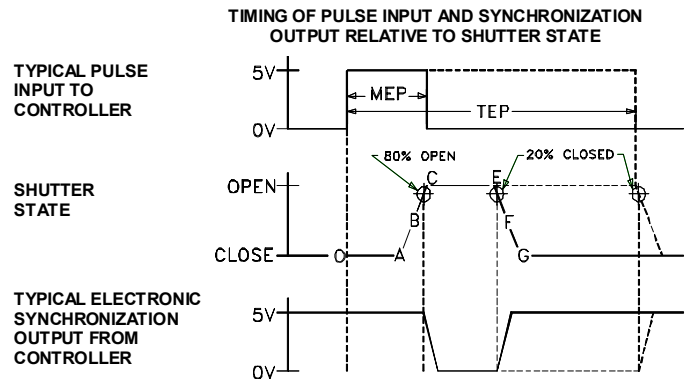

	HIGH	NORM
O-A Delay time on opening after current is applied	0.70	0.70
A-C Transfer time on opening	0.10	0.10
O-C Total opening time	0.80	0.80
B-F Min. equivalent exp. time	0.19	0.89
C-E Min. dwell time with min. input pulse	0.08	0.78
E-G Transfer time on closing	0.12	0.12
A-G Total window time	0.30	1.00
MET: Min. exposure time	0.80	0.80
TEP: Typical exposure pulse	N/A	>1.58

The question regarding enhancement of shutter speed with the application of user supplied lubricants has been repeatedly asked. It is our experience that lubricating the shutter blades will actually slow the shutter down and eventually render the shutter inoperable. UNDER NO CIRCUMSTANCES SHOULD ANY TYPE OF LUBRICANT BE APPLIED TO THE SHUTTER BLADE AREA.