

When operating this device without **UNIBLITZ**<sup>®</sup> drive equipment, (i.e. using a driver of your own design, etc.) please review these CS90 Shutter Electrical Configuration Layouts for proper CS90 system wiring. Improper connections made to this device can cause irreparable damage to the unit's integrated auxiliary actuator driver board. Due to the nature of the unit's design, please exercise anti-static protocol when handling this device. (Please note the 122-BP driver should not be used to operate the CS90 at this time. Only VMM and VCM type drivers are recommended to operate the CS90. For more information regarding the use of OEM drivers please contact technical support.)

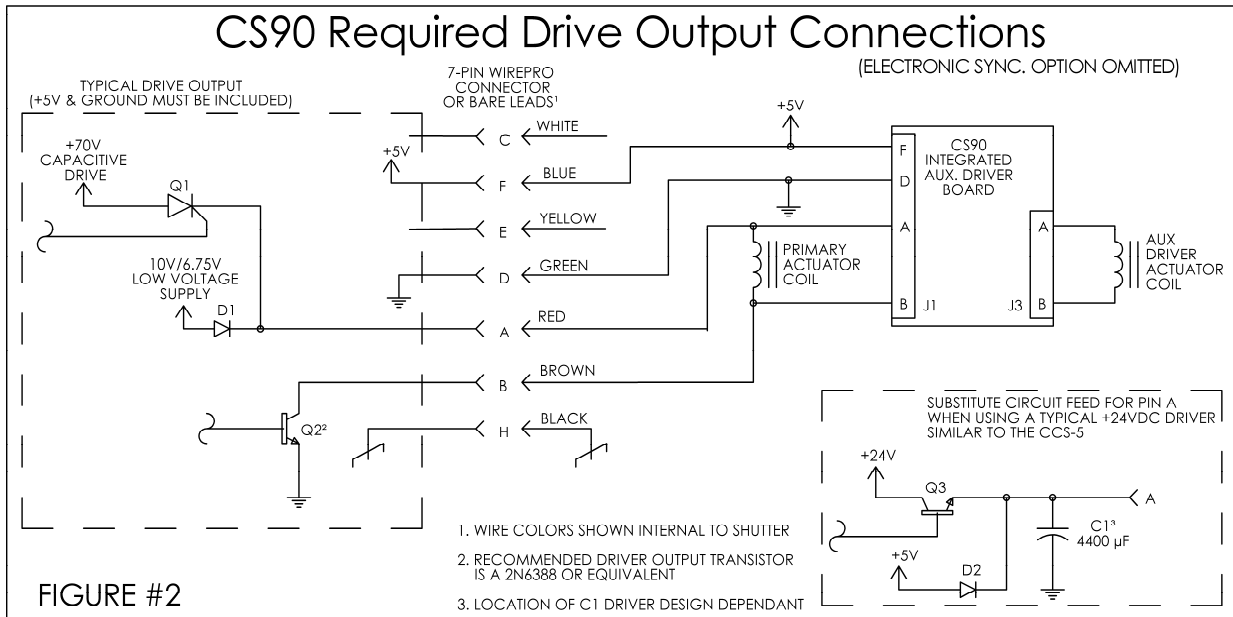
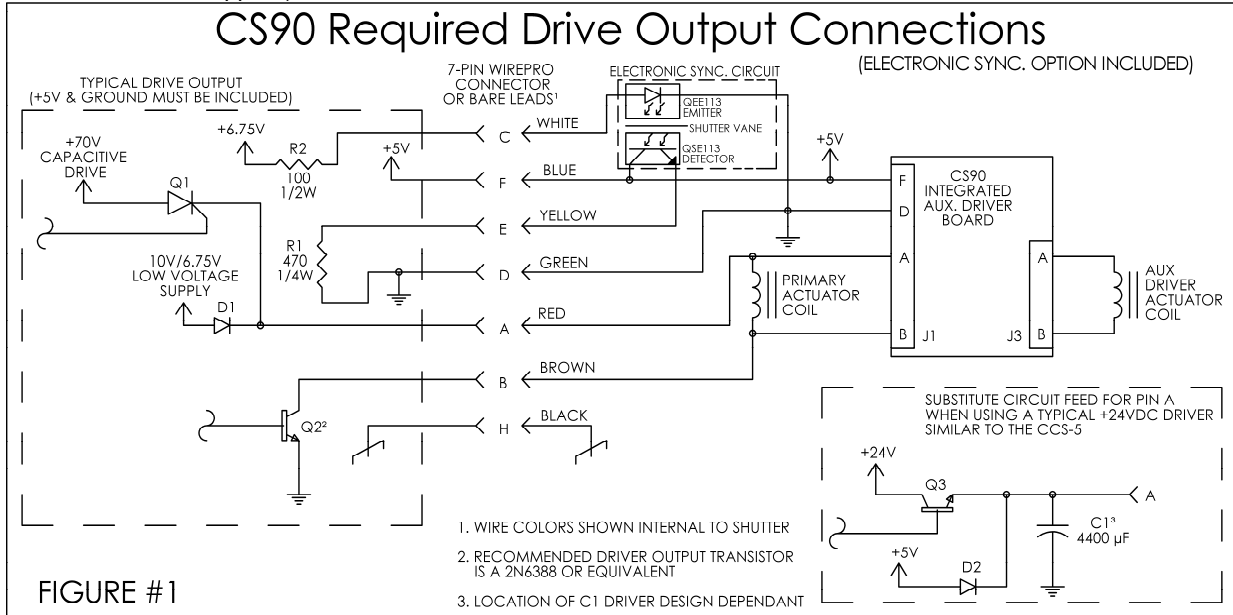

Figure 1 illustrates proper CS90 wiring with electronic sync option; figure 2 illustrates proper CS90 wiring without sync. Please contact our technical support staff if you have any questions concerning these configurations. See contact information above.

**DUE TO THE ACTUATOR CONFIGURATION AND THE ON BOARD AUX DRIVER, DO NOT USE THE 122-BP CONTROLLER TO OPERATE THE CS90. PLEASE CONTACT OUR TECHNICAL SUPPORT STAFF WHEN USING ANY OEM DRIVER DESIGN.**