



**UNIBLITZ**<sup>®</sup>  
Electro-Programmable Shutter Systems

## DSS10 Shutter Series Specifications

### Overview

The DSS series is the latest technology available from UNIBLITZ. This patent pending device has eliminated the external protruding actuator and contains no other interfering components. All drive and damping related components related to the mechanical motion of the shutter are contained or integrated within. The device can also be scaled for alternate aperture sizes to further tailor the device for the most demanding customer applications.

The DSS10 is presently the smallest device in the DSS series. The DSS10 is a bi-stable shutter and no power is required to hold the shutter in either the open or closed state. Power is required only to change the state of the device. There are no dimensional changes associated with this configuration and it can be driven by the ED12DSS driver board.

The reliability of this device has been enhanced by containing only two unique moving parts (the drive ring and the blades). This in conjunction with their bi-stable operation (and when driving the shutter with the new ED12DSS +12VDC driver) has provided the most reliable device of its kind available.

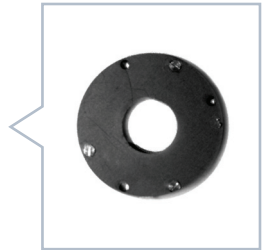

### Features

- **Flat Mounting Surfaces On Both Sides Of The Device**  
There are no protruding components allowing flush mounting on either side of the device.
- **Easily Integrated Into Customer Applications**  
Circular envelope and concentric aperture allow for easy and fast integration into customer specific applications.
- **Scalable Design**  
Simplicity of design allows for unprecedented ease of scaling from apertures as small as 10mm.
- **Low Cost For A Custom Aperture**  
Until now a redesign for specific aperture openings of a shutter device would incur substantial NRE (Non-Recurring Engineering) costs. The DSS shutter is specifically designed to take advantage of its versatility.
- **Can Be A Replacement For Existing Flag Shutters**  
Flag shutter devices are difficult to design on center and require additional offset space in a camera for the actuator. DSS devices can be centered on aperture and hence the overall space required for a given aperture is substantially less.
- **Blades Can Be Coated For Ir Applications**  
DSS Shutters are particularly suited for Non-Uniformity Correction applications.
- **Two Distinct Moving Parts**  
The drive ring and the blades are the only parts in motion limiting points of wear.
- **Low Voltage Or Low Current Operation**  
Bi-stable operation significantly reduces power draw. The DSS10 can be designed to take advantage of your particular system, whether it is battery powered or takes power from line voltage.

## DSS10 – Product Specifications

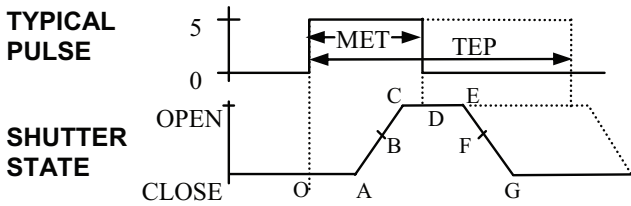

### DSS10 Timing Data in msec

Timing data recorded with ED12DSS driver with drive pulse equal to MET.

O-A: Delay time on opening after current is applied	3.6
A-C: Transfer time on opening	5.0
O-C: Total opening time	8.6
C-E: Min. dwell time with min. input pulse	5.0
B-F: Min. equivalent exp. time	10.0
D-E: Delay time on closing after current is applied	3.6
E-G: Transfer time on closing	5.0
A-G: Total window time	15.0
MET: Min. exposure time	15.0
TEP: Typical exposure pulse	>15.0

The question regarding enhancement of shutter speed with the application of user supplied lubricants has been repeatedly asked. It is our experience that lubricating the shutter blades will actually slow the shutter down and eventually render the shutter inoperable. UNDER NO CIRCUMSTANCES SHOULD ANY TYPE OF LUBRICANT BE APPLIED TO THE SHUTTER BLADE AREA.

### DSS10 Electrical Specifications

COIL RESISTANCE: 8 OHMS  
PULSE VOLTAGE: 12V

### DSS10 Mechanical Specifications

WEIGHT: 4.9g  
TEMPERATURE RANGE: 0-80C  
OPEN BOUNCE: 15%  
CLOSE BOUNCE: 5%  
NUMBER OF BLADES: 4  
CONTINUOUS FREQUENCY: 10HZ  
BURST FREQUENCY: 20HZ

Continuous frequency rating specified at shutter's minimum exposure pulse. BURST frequency rating specified for (4) four seconds maximum with (1) one minute minimum between bursts. Frequency measurements are taken in free air and 25°C ambient. For additional information on maximum sustained frequencies obtainable, please contact one of our technical representatives.

## DSS10 – Shutter Outline Drawing

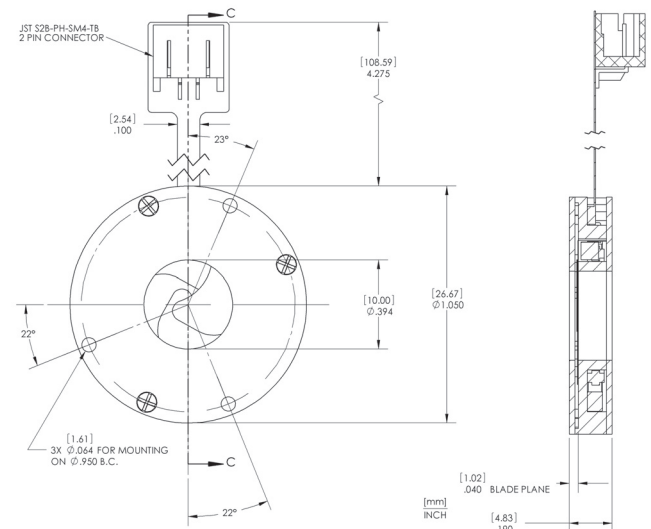

FIGURE #1

The DSS10 shutter device weighs 4.9g and is only 1.050" in diameter. You will notice that there are no other interfering components that will impede mounting the unit to any flat surface. It is easily mounted into an optical system via the three .064 inch diameter mounting holes at the locations shown in figure #1. Presently the unit will terminate to a 2-pin JST connector (S2B-PH-SM4-TB) via a 4 inch flex interconnect.

### DSS10 Product Options

DSS10B	1	T	0	
Aperture Size	Housing	Blade Finish	Electronic Sync	Connector
DSS10B-10mm	1-Un-housed	T-Black both sides Z-AISiO Coated* ZM-AIMgF2 Coated*	N/A	Included on four inch flex cable harness

\*Input side only, black coating is on opposite side. Intended to protect the shutter blade surface. The light source must be input to the reflective side only.



803 Linden Avenue  
Rochester, NY 14625  
[www.Uniblitz.com](http://www.Uniblitz.com)

585-385-5930 tel  
800-828-6972 toll-free  
585-385-6004 fax

Brought to you by Vincent Associates